

Decay Spectroscopy with EURICA in the region of ^{100}Sn

Daniel Lubos for the EURICA RIBF09 collaboration
Technische Universität München
Jul 09, 2015 @ Science Day of RA G
Excellence Cluster *Origin and Structure of the Universe*

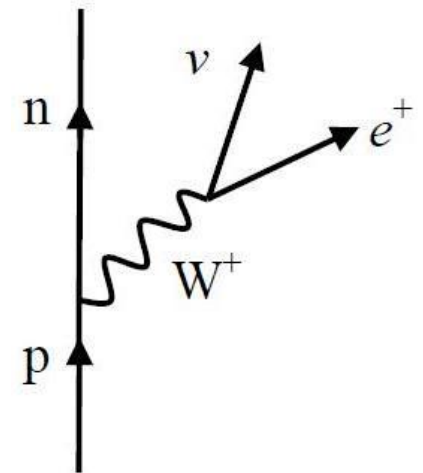

Contents

- **Introduction**
- **Facility & Detectors**

- **Lifetimes**
- **The β -Endpoint-Energy**
- **Further Nuclei: ^{94}Ag**

- **Discussion**

Introduction

Why we need β -decay spectroscopy – The region around ^{100}Sn

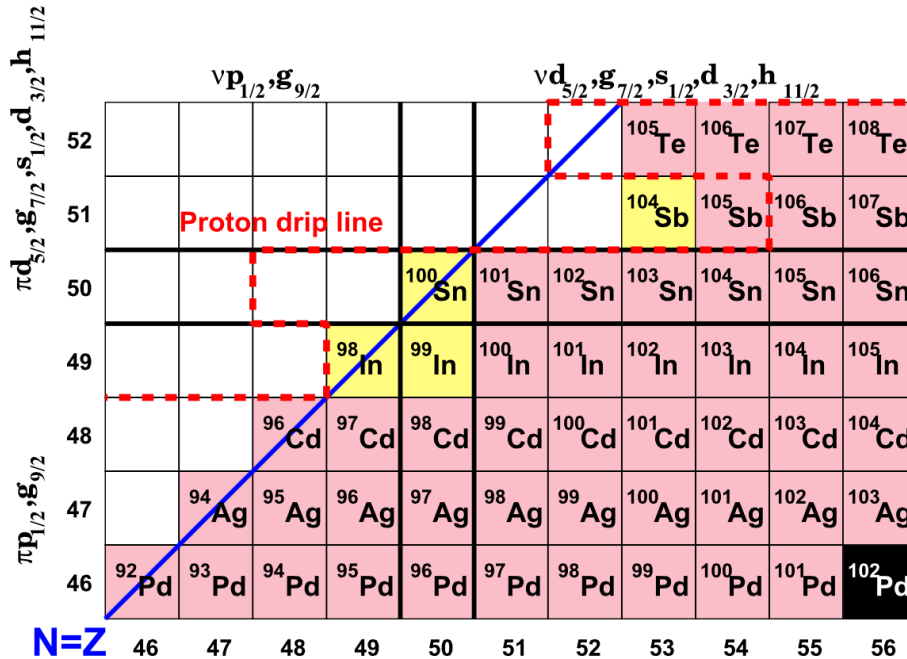

- β -decay systematics
- nuclear structure
- accurate lifetime
- rp-process
- proton dripline
- transition strength B

Experiment

- Lifetime
- Q_β -value

→ B_{GT}

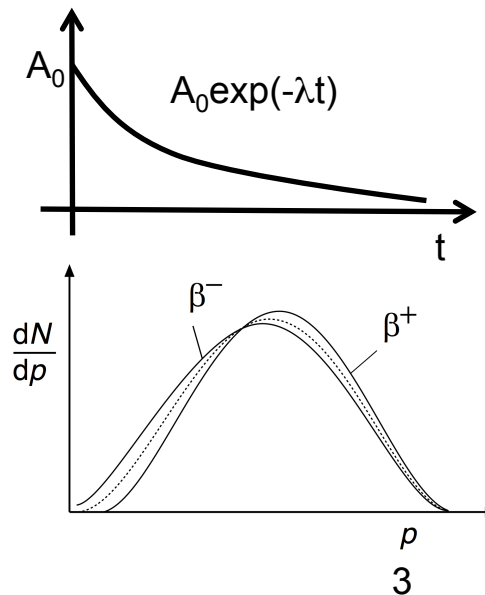

Shell Model & β -Decay

Super-allowed β -decay

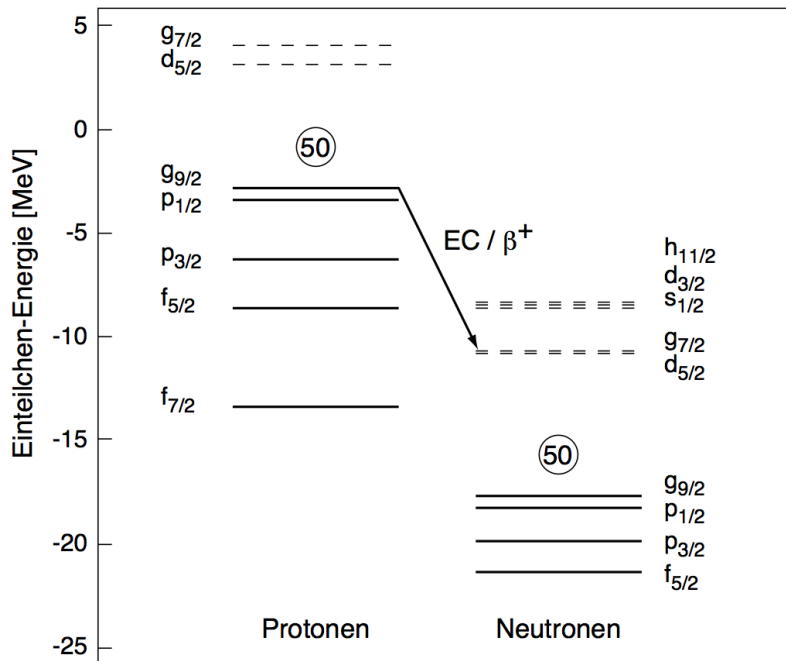

Source: A. Stolz, PhD-thesis TUM (2001)

Selection Rules:

Fermi Decay

$$\uparrow \rightarrow \uparrow + \uparrow\downarrow \quad \Delta T = 0, \Delta I = 0$$

$$\mathcal{B}_F = |\mathcal{M}_v|^2 = |\langle \psi_f | \tau_{\pm} | \psi_i \rangle|^2$$

Gamow Teller Decay

$$\uparrow \rightarrow \downarrow + \uparrow\uparrow \quad \Delta T = 0, \pm 1, \Delta I = 0, 1$$

$$\mathcal{B}_{GT} = |\mathcal{M}_a|^2 = |\langle \psi_f | \sigma \tau_{\pm} | \psi_i \rangle|^2$$

Facility & Detectors

The BigRIPS Facility @ RIKEN Nishina Center, RIBF

Primary Beams @ RIBF

Nucleus	Beam Intensity / pA	
	achieved	expected 2011
^{48}Ca	230	200
^{86}Kr	30	30
$^{124,136}\text{Xe}$	38 (~36)	10
^{238}U	0.8	5

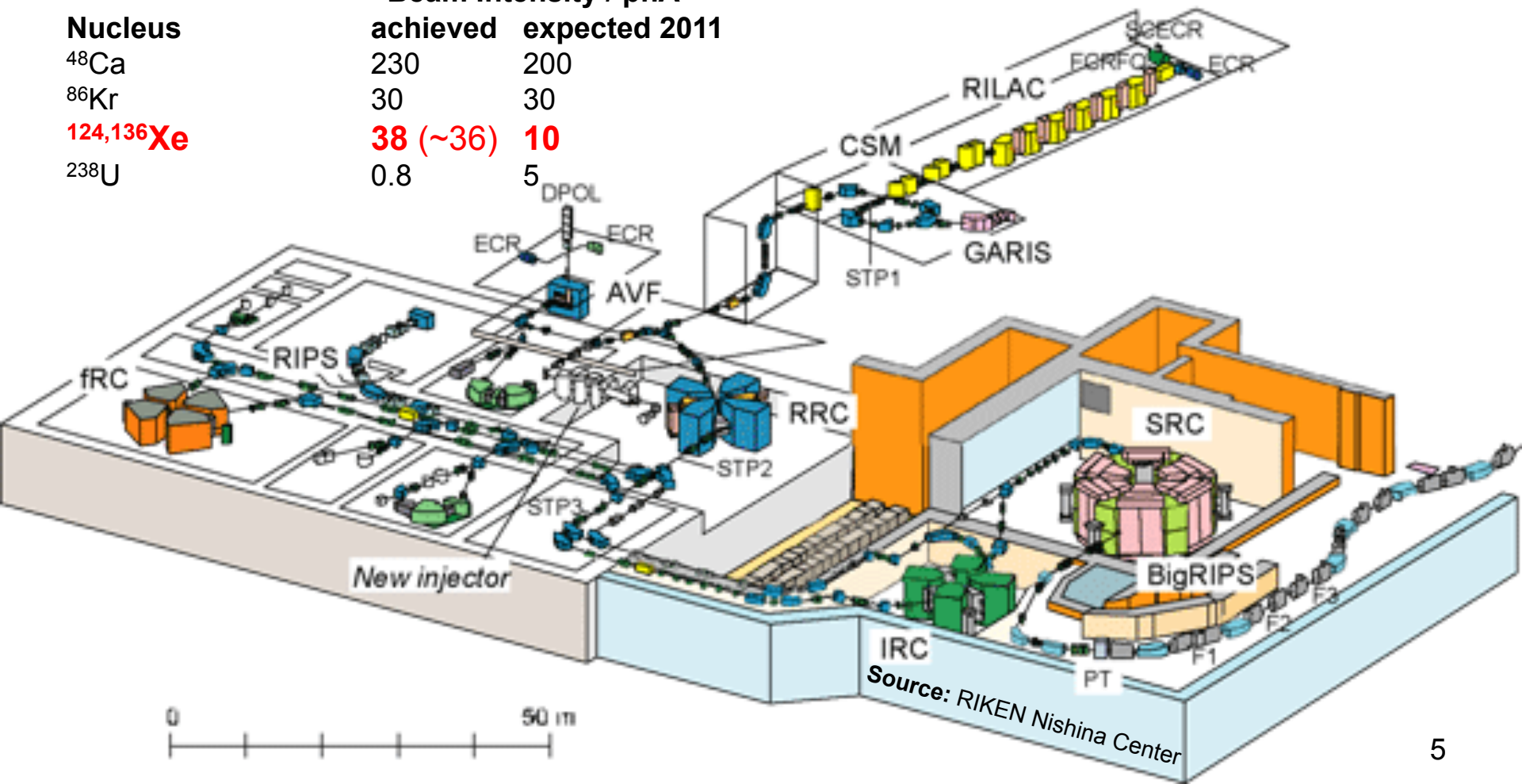

Facility & Detectors

The BigRIPS Facility @ RIKEN Nishina Center, RIBF

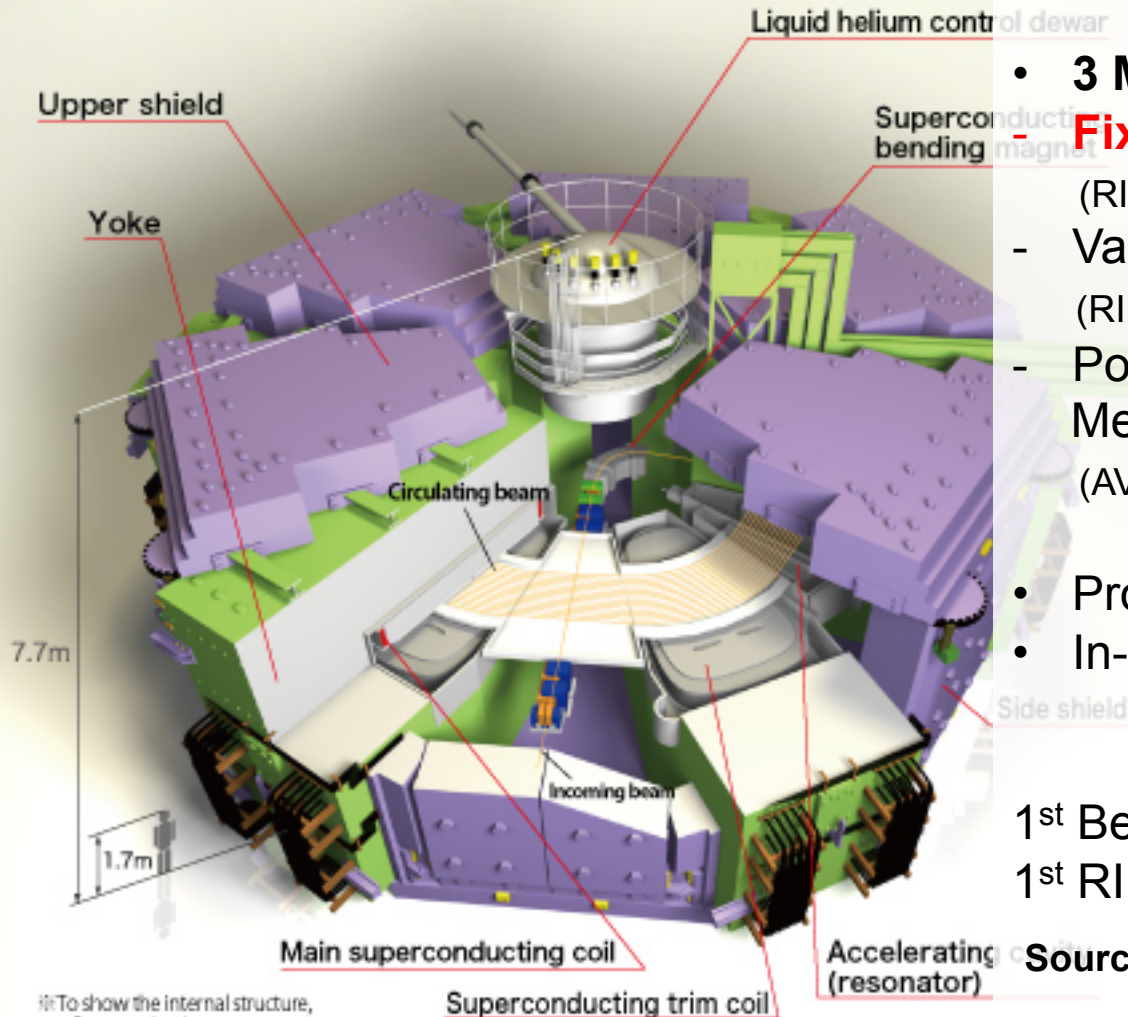

To show the internal structure, a front section is cut away.

- **World's first ring cyclotron with superconducting sector magnets**
- K-value 2500 MeV, 3.8 T, 235 MJ
- 8300 t

• 3 Modes

- **Fixed beam energy (350 MeV/u)**
(RILAC, RRC, fRC, IRC, SRC)
- Variable beam energy (115 MeV/u)
(RILAC, RRC, IRC, SRC)
- Polarized Deuteron Beam (880 MeV)
(AVF, RRC, SRC)
- Projectile Fragmentation
- In-flight fission of U-238

1st Beam: Dec 28, 2006
1st RI Beam: Mar 15, 2007

• **Source:** RIKEN Nishina Center

Source: RIKEN Nishina Center

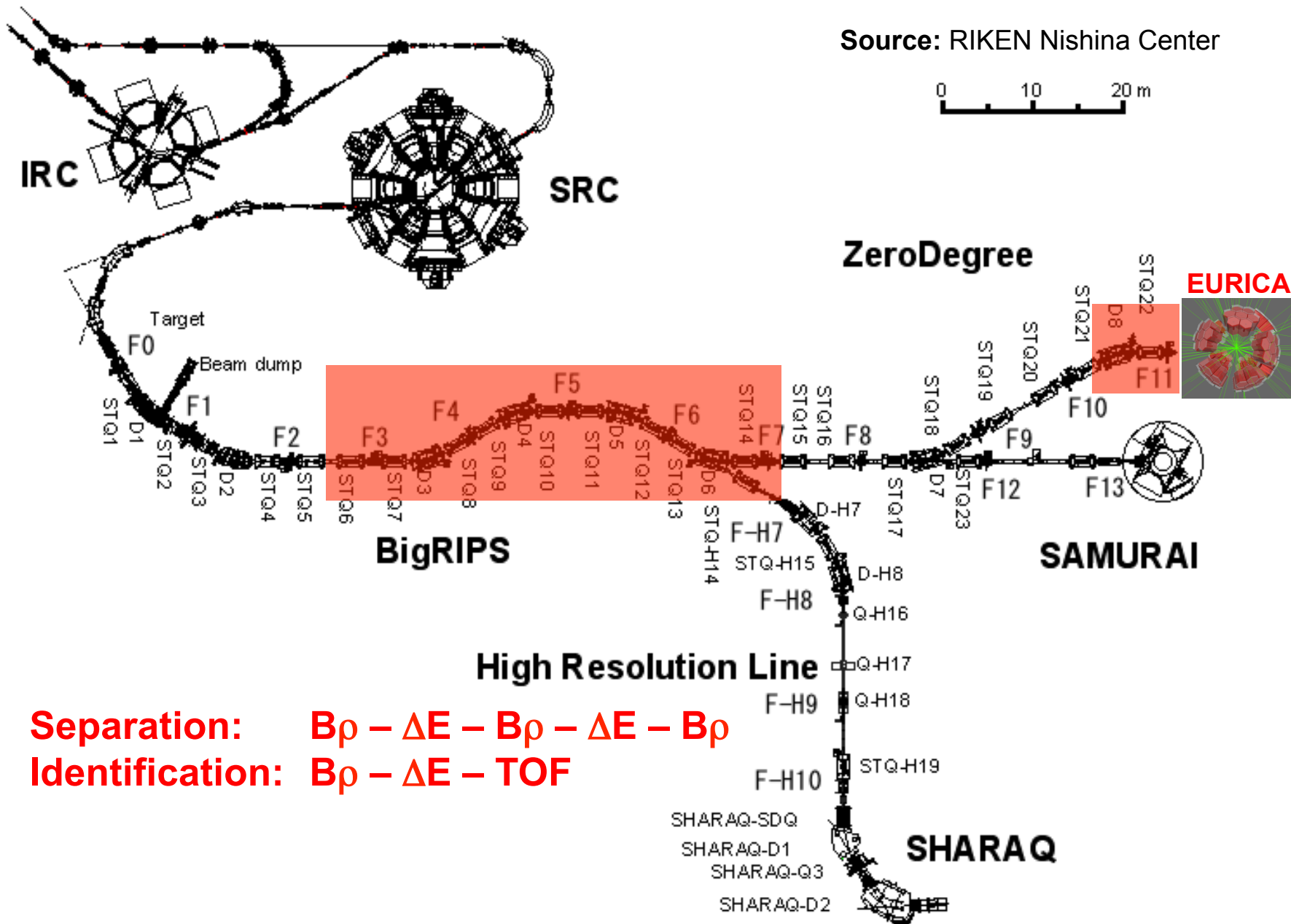
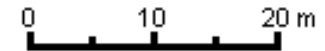

Facility & Detectors

The EURICA Gamma-ray Detector Cluster

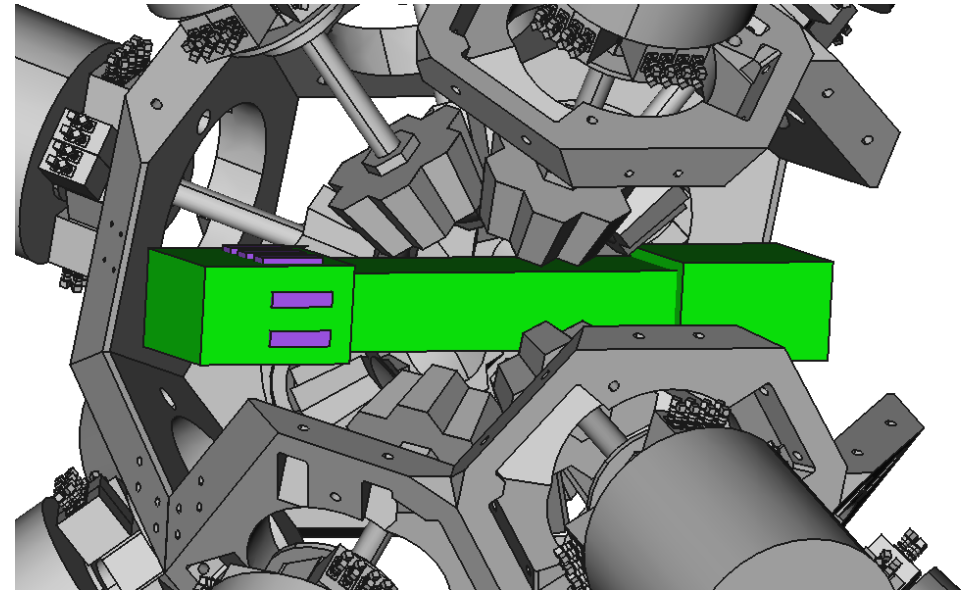
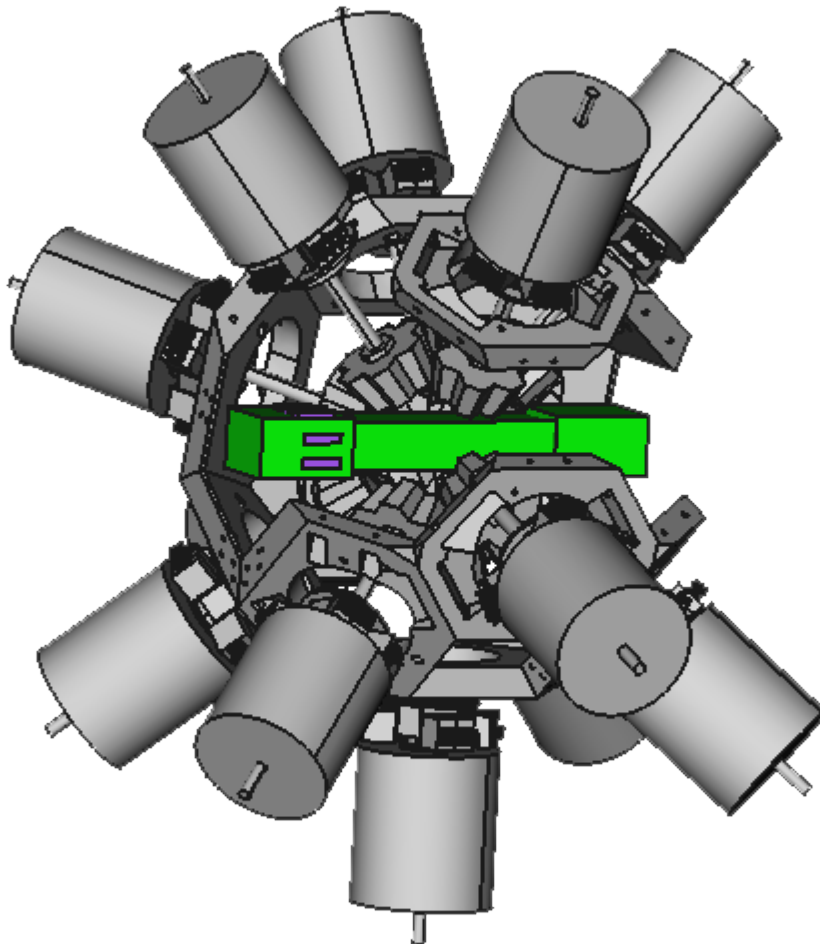

Courtesy by G. Lorusso, S. Nishimura

EUROBALL as used in RISING @ GSI
12 clusters of 7 HPGe Crystals each
3 clusters with 6 LaBr Crystals each

Energy Resolution ~ 2 keV
Timing Resolution ~ 25 ns

Operated at 4 KV

Facility & Detectors

The EURICA Gamma-ray Detector Cluster

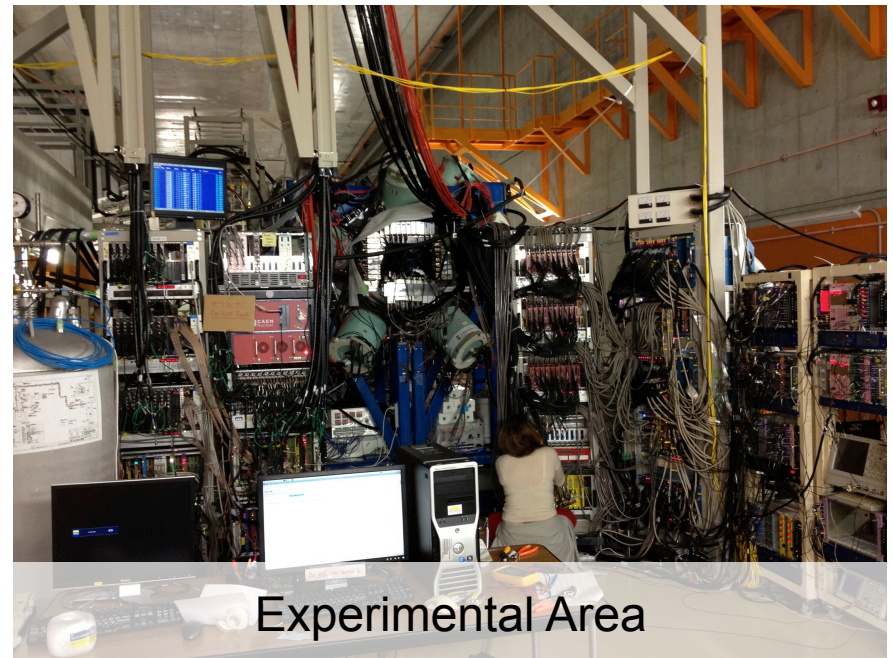
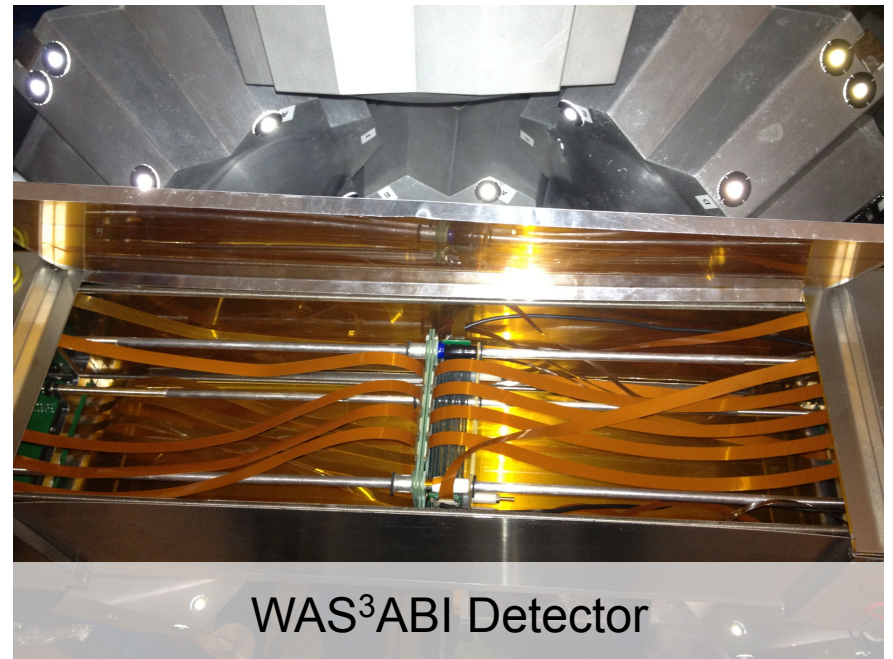
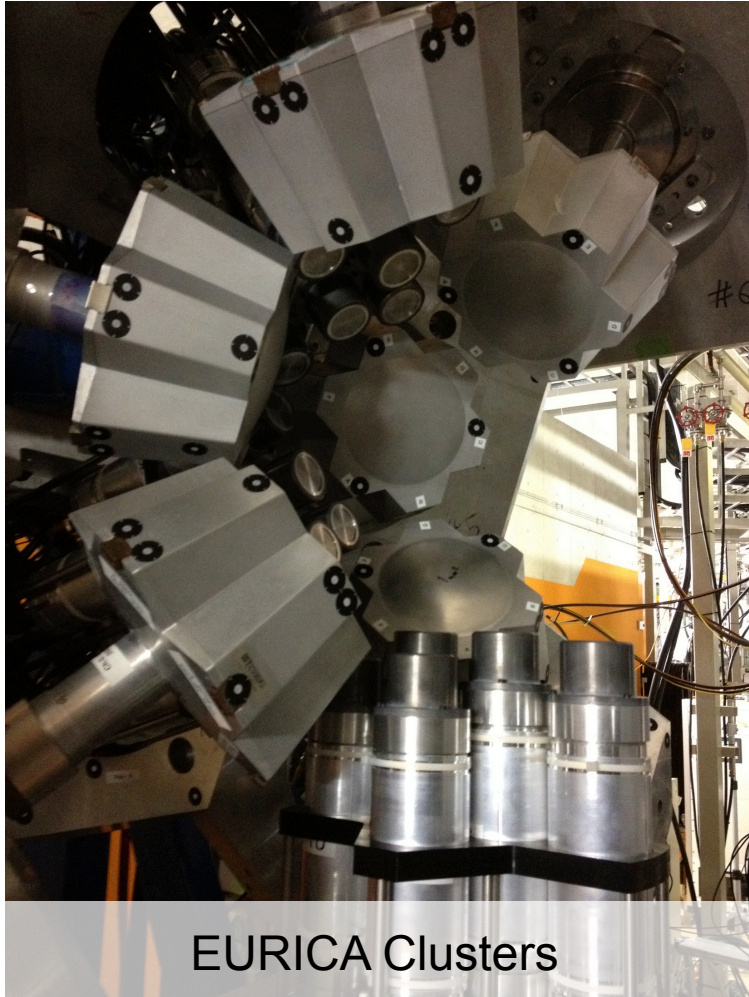

Facility & Detectors

The WAS³ABI Silicon Detector Array

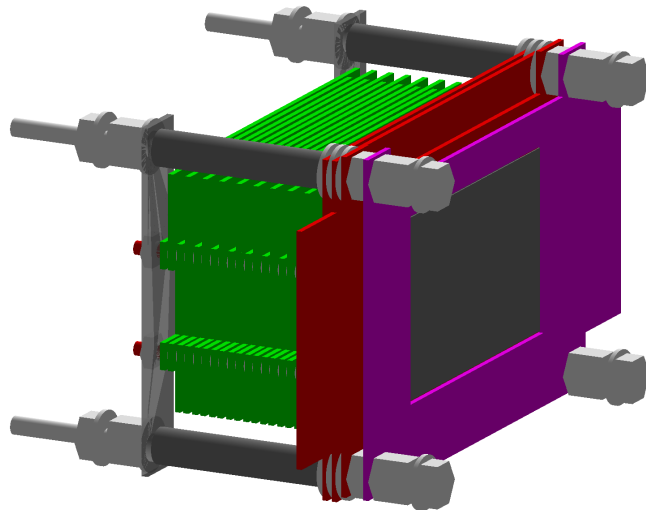

Decay (green)	Implantation (red)	Beam tracking (purple)
10 x 1 mm	3 x 1 mm	1 x 0.3 mm

3 **D**ouble-**S**ided **S**ilicon **S**trip **D**etectors (DSSD)
 10 **S**ingle-**S**ided **S**ilicon **S**trip **D**etectors (SSSD)

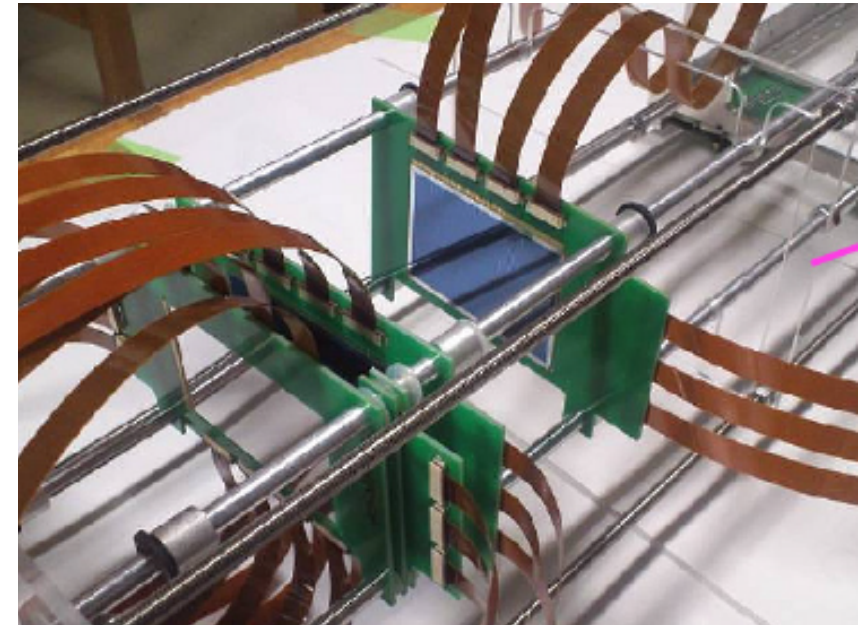

Area: 60 mm x 40 mm

Segmentation:

DSSD 60 strips X 40 strips

SSSD 7 strips

Width: 1 mm (compare: e⁻ mean free path: 1 mm)

TOTAL: 380 Channels

Facility & Detectors

New Isotope Search - Finalized

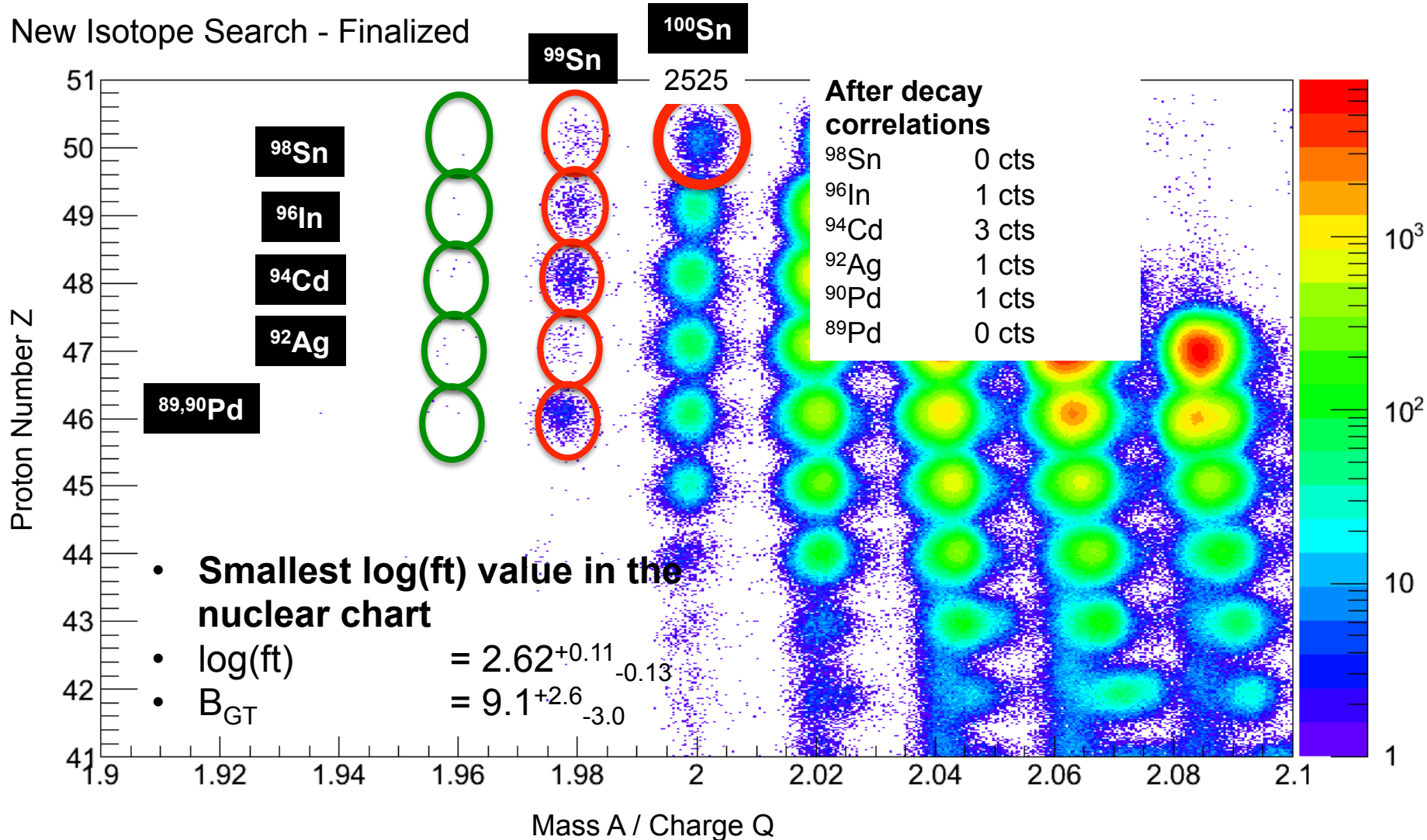

Results

Lifetime of ^{100}Sn

$$\mathcal{B}_{\text{GT}} = \frac{3811.5 \text{ s}}{f(Z', \epsilon_0) \cdot t_{1/2}}$$

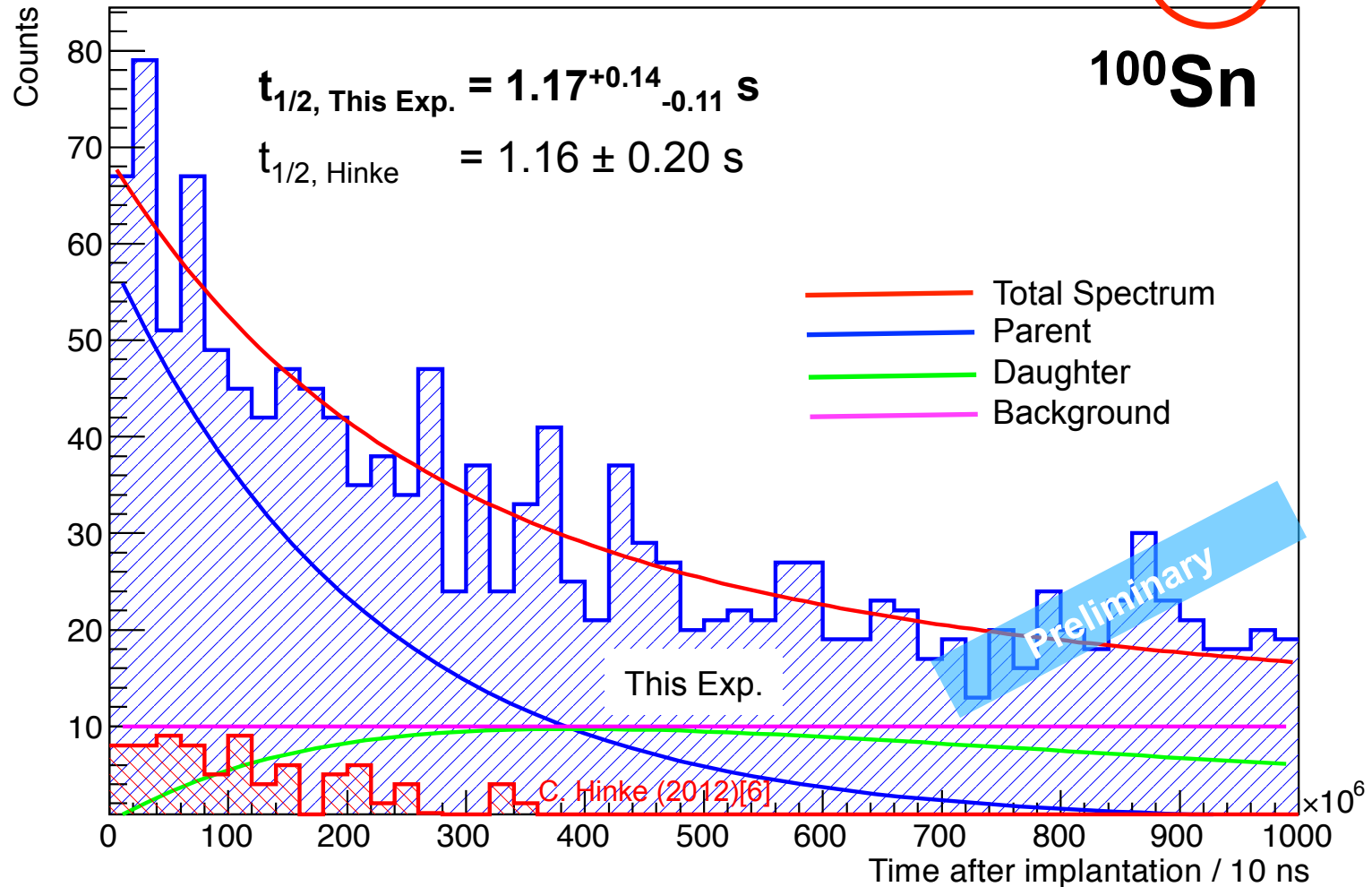

Results

Background reduction by event selection

Time spectrum of ^{100}Sn β -decay/ 10 ns

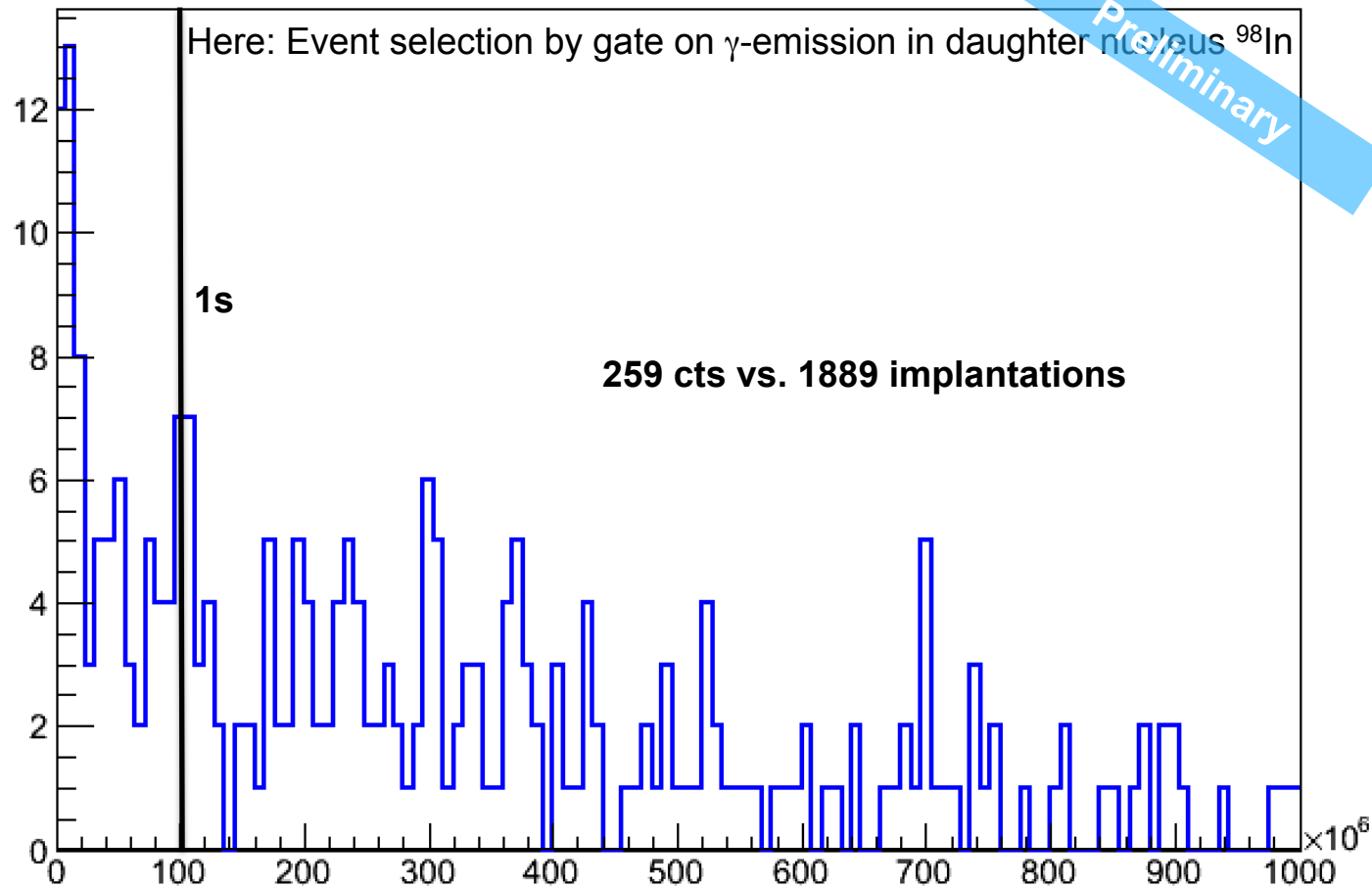

Results

β -endpoint-energy

- Second part regarding the determination of B_{GT}

Distinguish

- Implantation events
- Decay events
- Light particle events

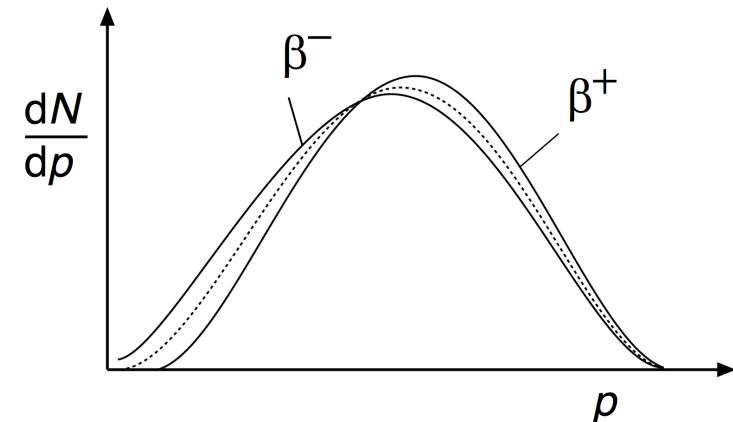

- Event tracker to judge each event
(spatial correlation, time correlation, energy discrimination, pattern analysis)

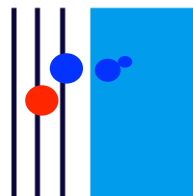
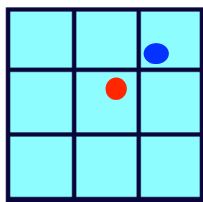

MAX

**empty
MULT
Gap**

- “Clean” (background reduced) spectrum in order to determine Q_{β} -value

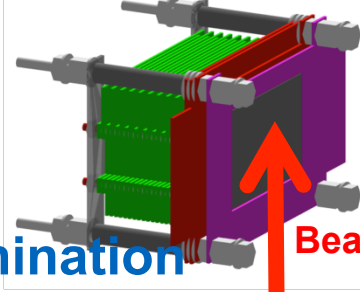

Beam direction Z

Results – Particle Discrimination

Event Tracker

Decay Event

Light Particle Event

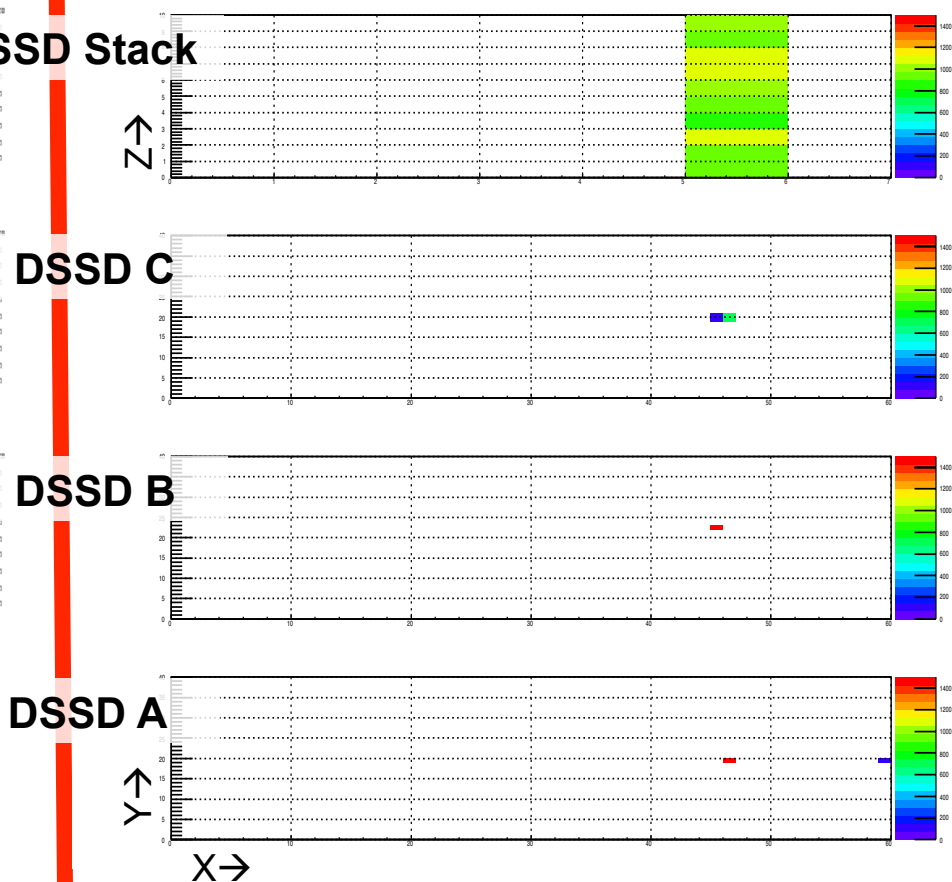
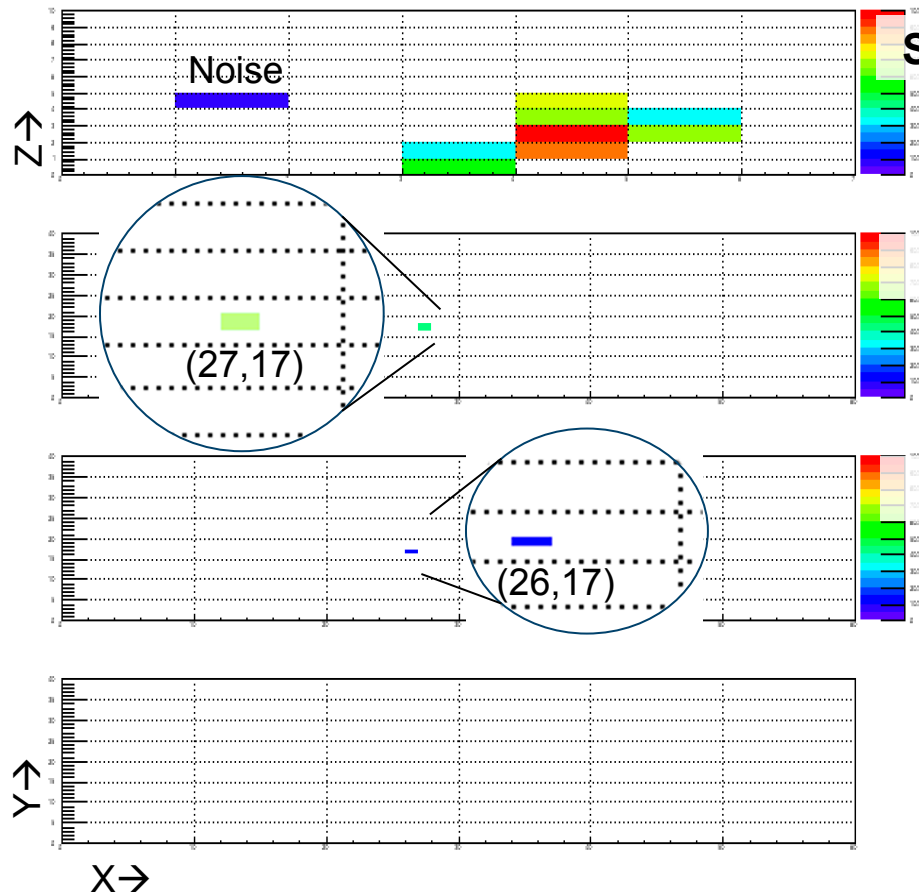

Results

First β -Endpoint-Energy Spectrum

$$B_{GT} = \frac{3811.5 \text{ s}}{f(Z', \epsilon_0)} \cdot t_{1/2}$$

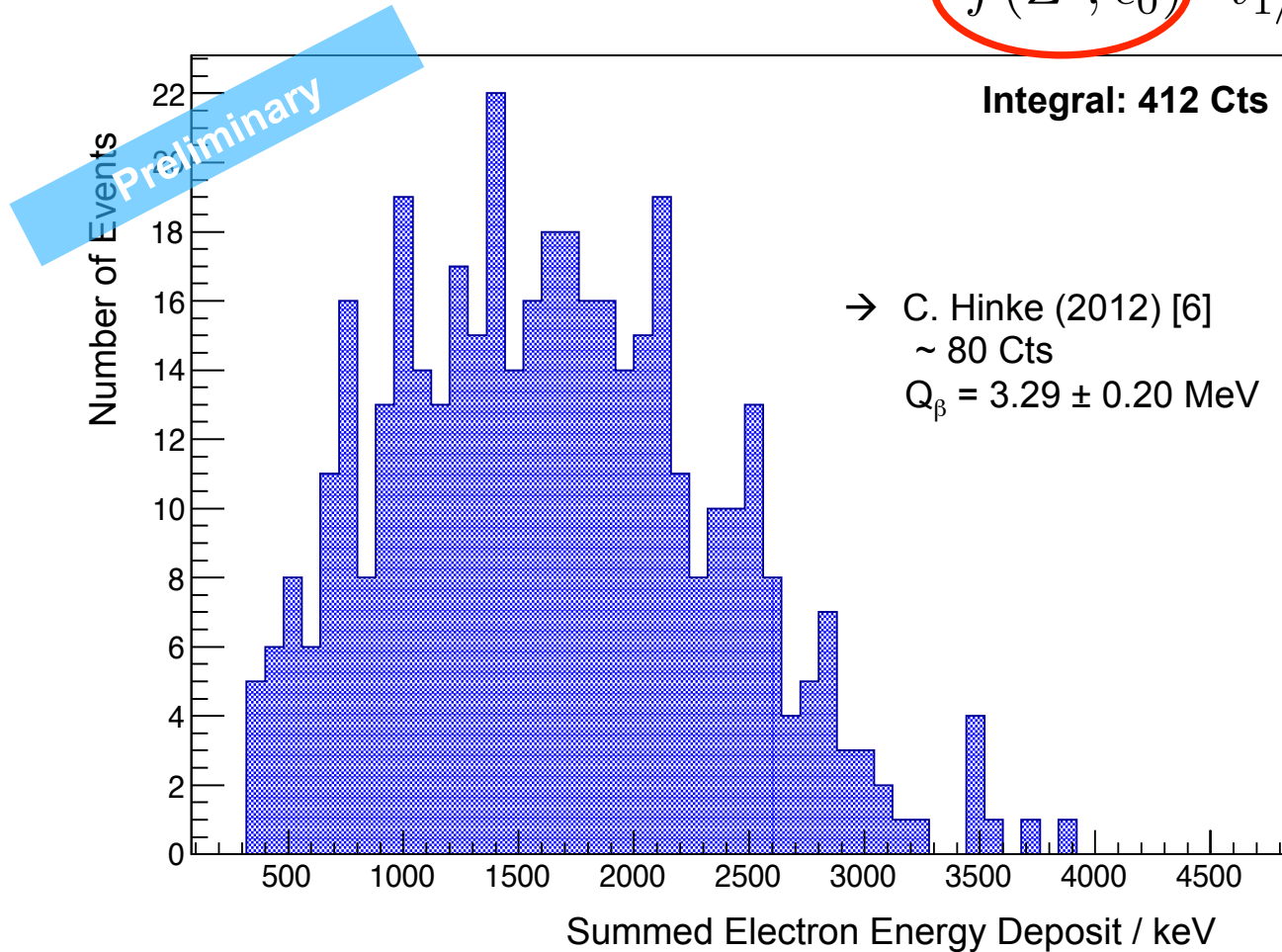

Results

First β -Endpoint-Energy Spectrum

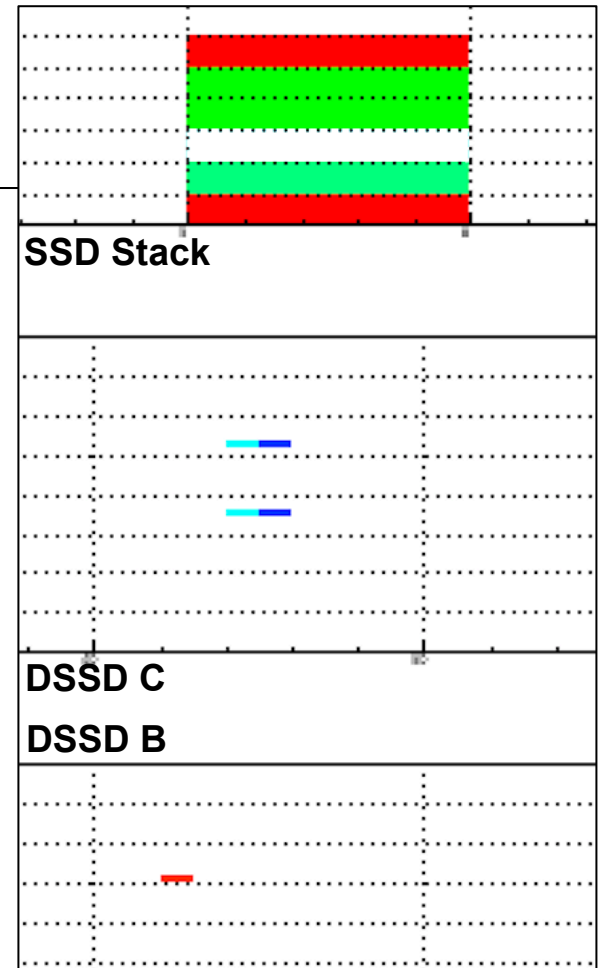
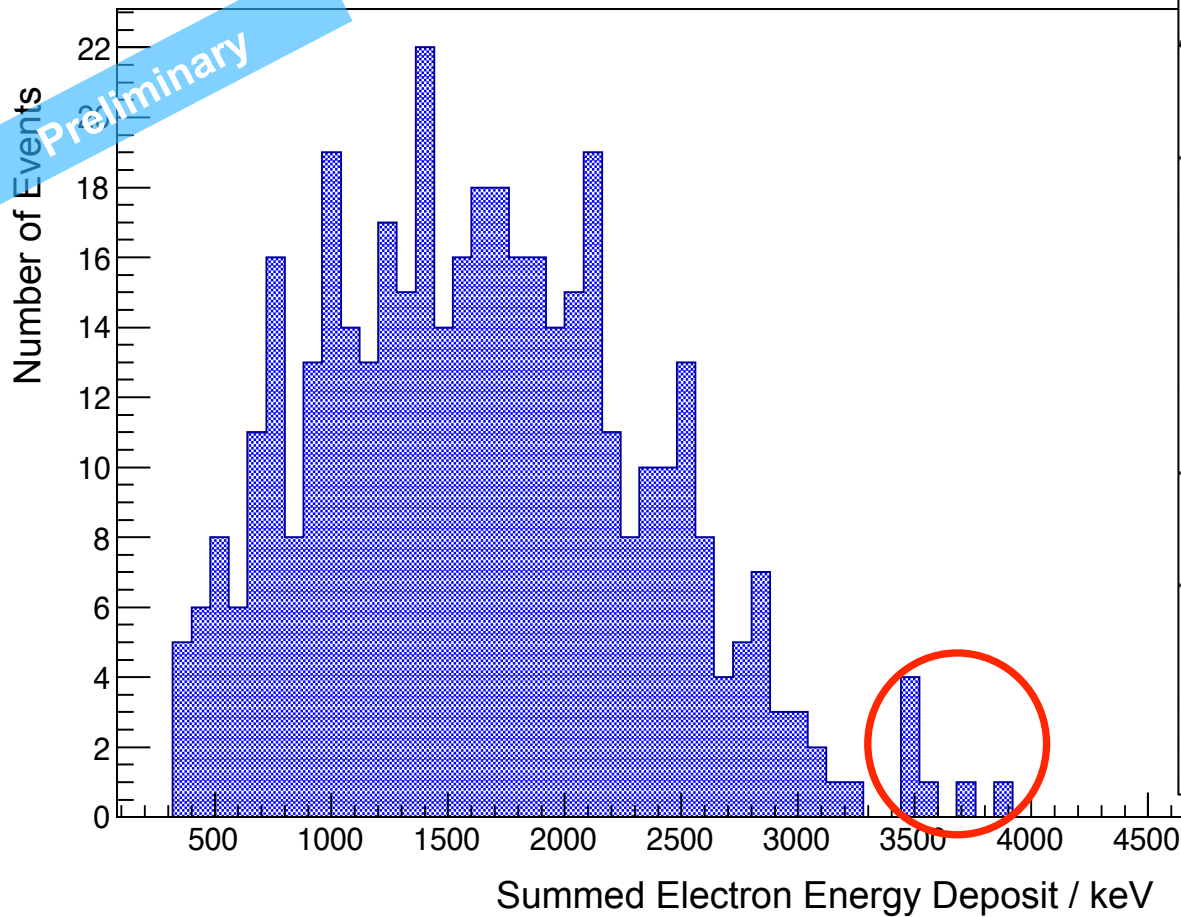



Results – Beyond the N = Z line

Lifetimes of N = Z – 1 nuclei using MLH method

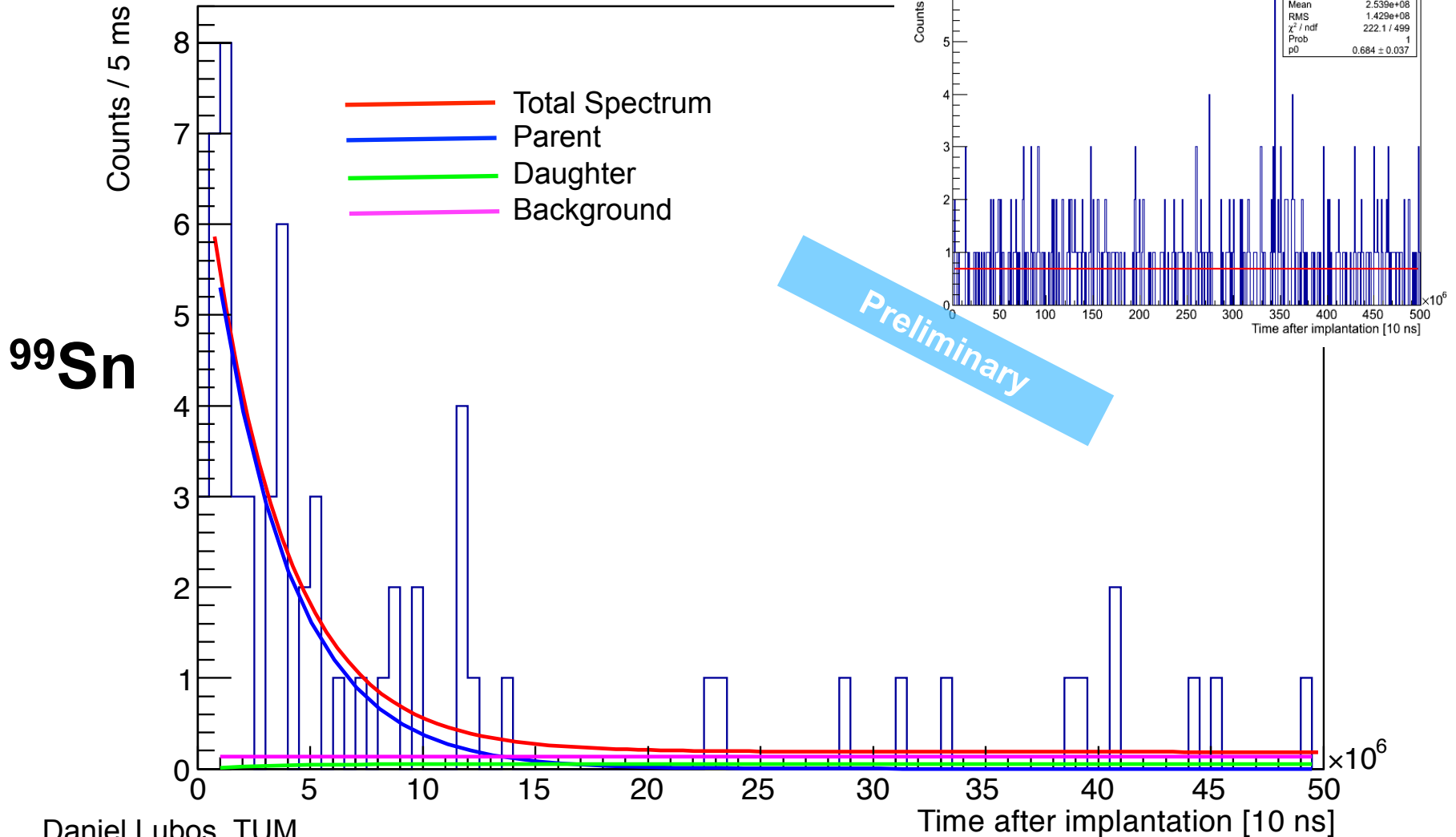

Lifetime Determination of Sn99 (BG)

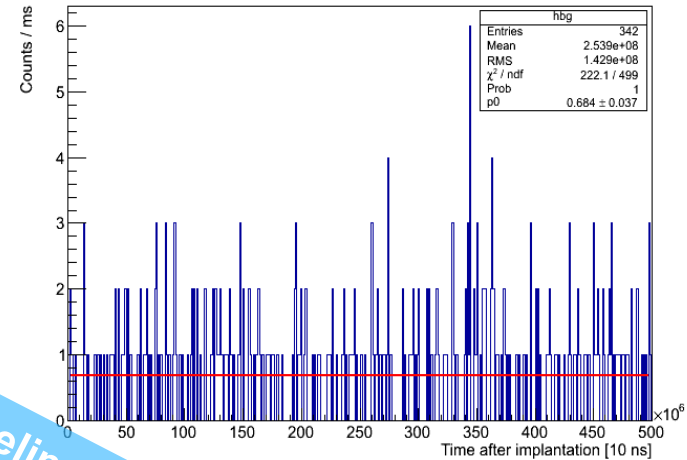

Preliminary

Results – Beyond the N = Z line

Lifetimes of N = Z – 1 nuclei using MLH method

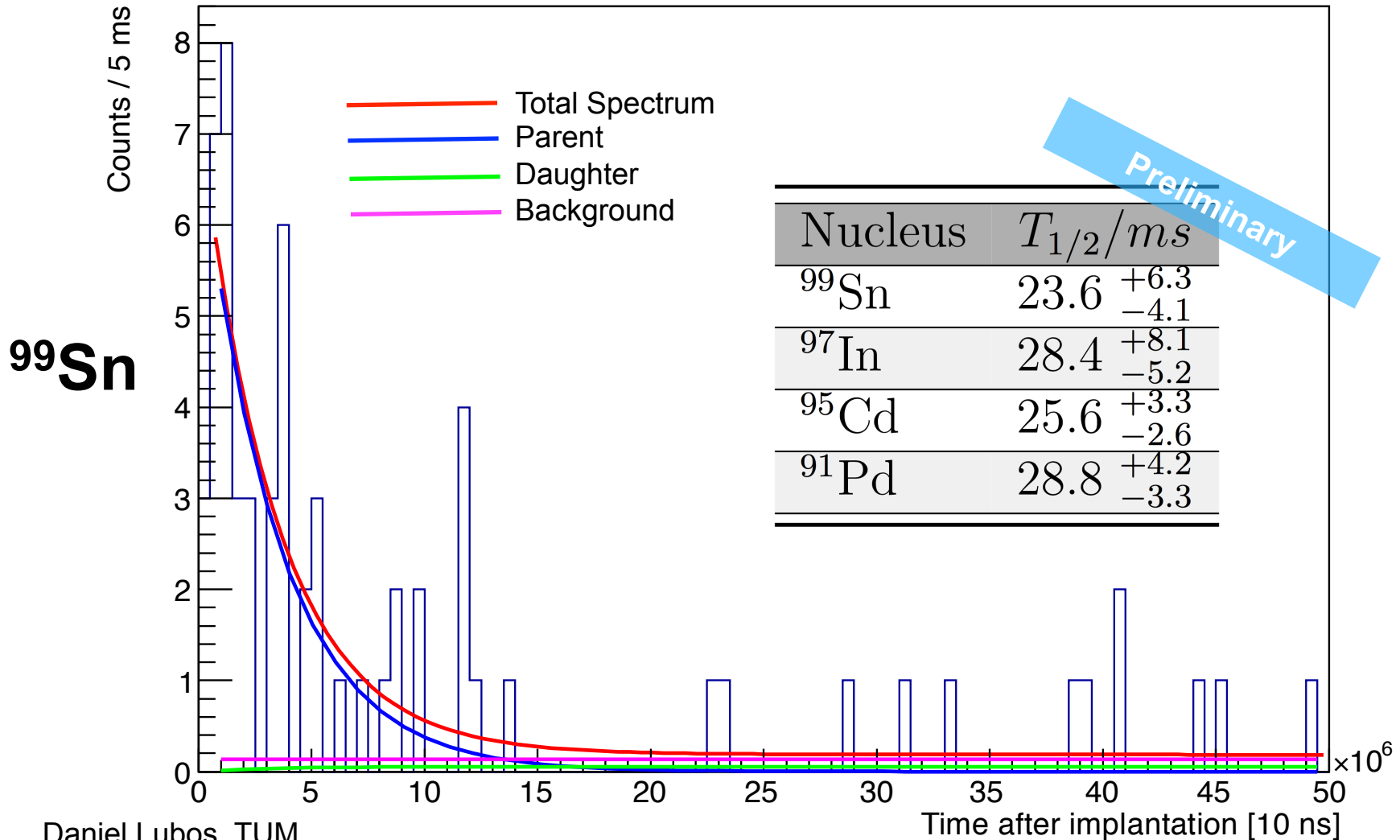

Further Nuclei: ^{94}Ag

Study of Decay Channels

	ϵ ϵ_p	ϵ : 100.00% ϵ_p : 12.0%	ϵ : 100.00% ϵ_p : 12.0%
^{93}Ag	^{94}Ag 26 MS	^{95}Ag 1.75 S	^{96}Ag 4.40 S
ϵ_p ϵ	ϵ : 100.00% ϵ_p	ϵ : 100.00% ϵ_p	ϵ : 100.00% ϵ_p : 8.50%
^{92}Pd 0.7 S	^{93}Pd 1.01 S	^{94}Pd 9.6 S	^{95}Pd 5 S
ϵ : 100.00%	ϵ : 100.00% ϵ_p	ϵ : 100.00%	ϵ : 100.00%
^{91}Rh 1.47 S	^{92}Rh 4.66 S	^{93}Rh 12.2 S	^{94}Rh 66 S
ϵ	ϵ : 100.00%	ϵ : 100.00%	ϵ : 100.00% ϵ_p : 1.80%

Decay channels of ^{94}Ag

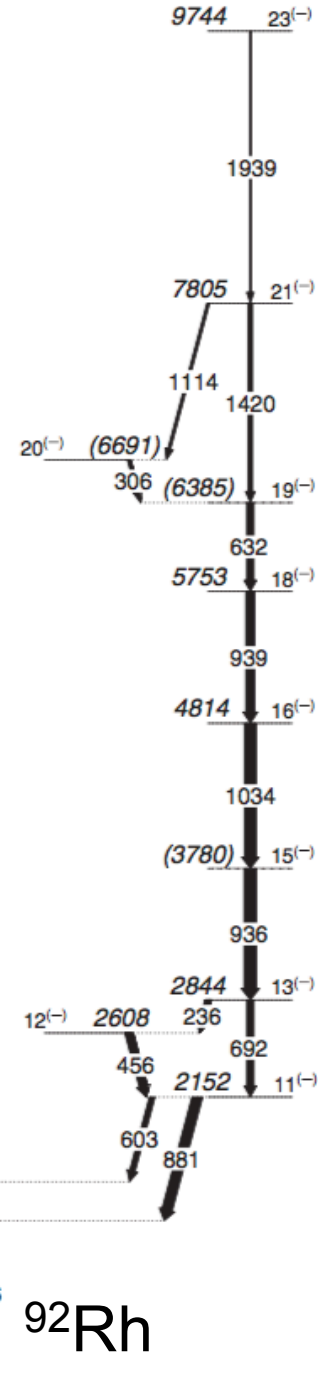

Occupation Scheme

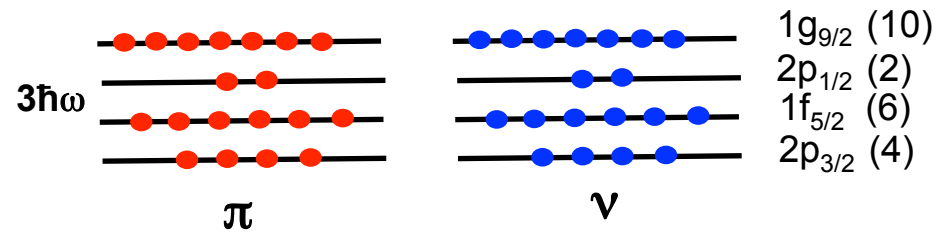

Level Scheme

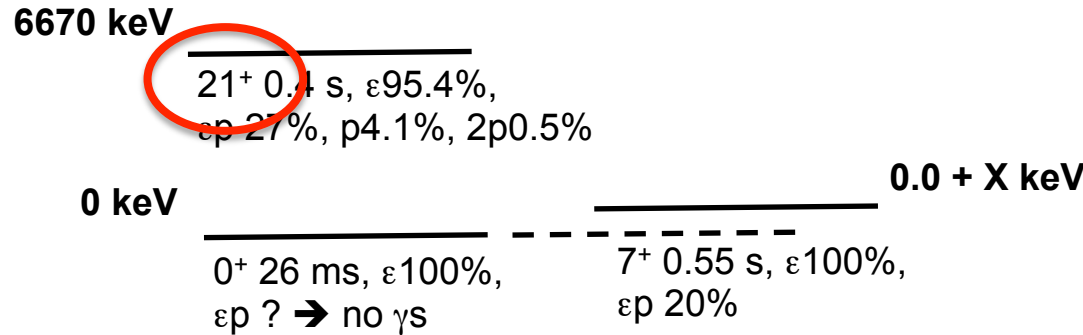

^{94}Ag 21⁺ show 2p decay to ^{92}Rh
Highest known spin-isomer

[1] I. Mukha et al., Nature 439 (2006) 298



Further Nuclei: ^{94}Ag

Half-life, two parent components

Time after implantation / 10 ns

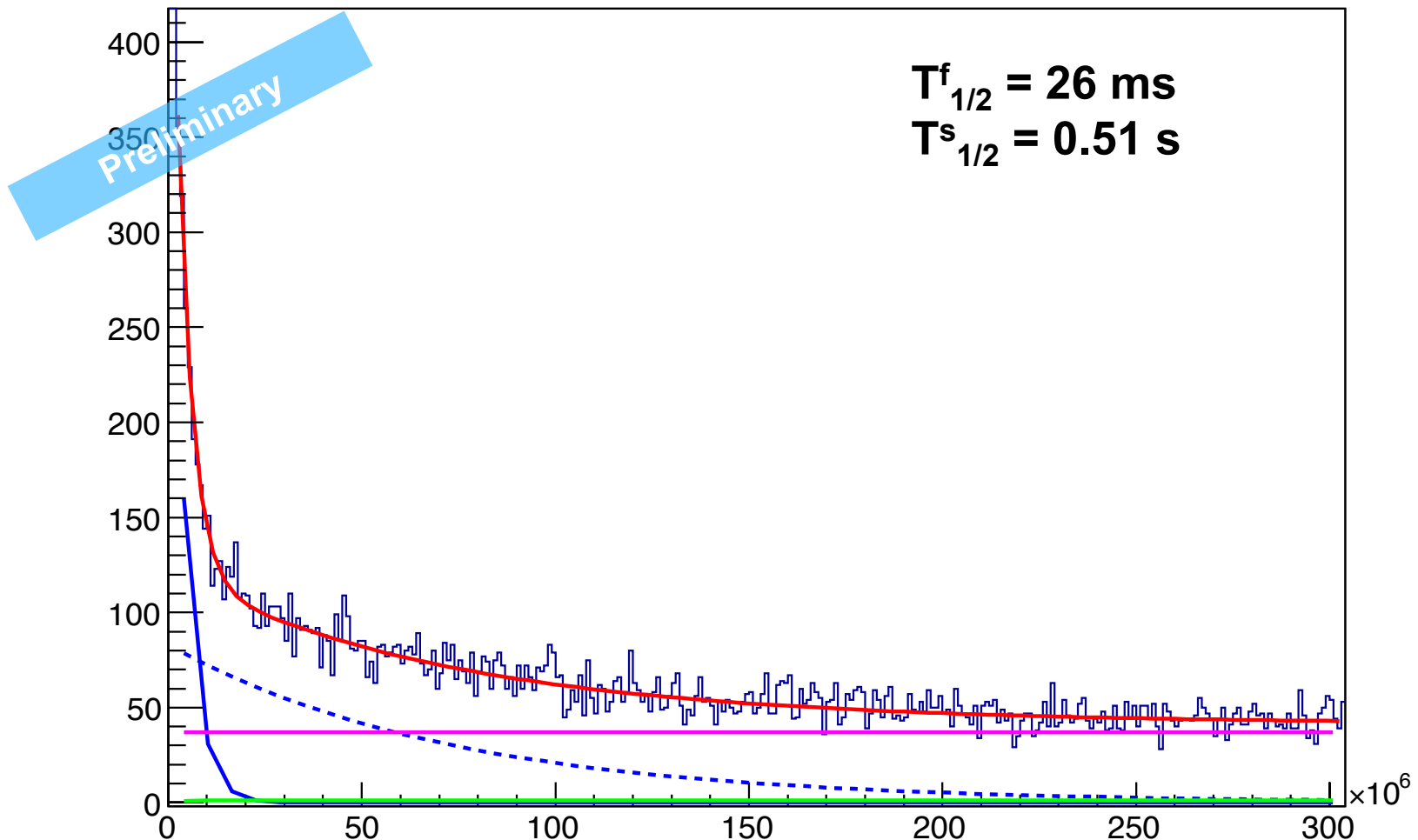

Further Nuclei: ^{94}Ag

Study of Decay Channels

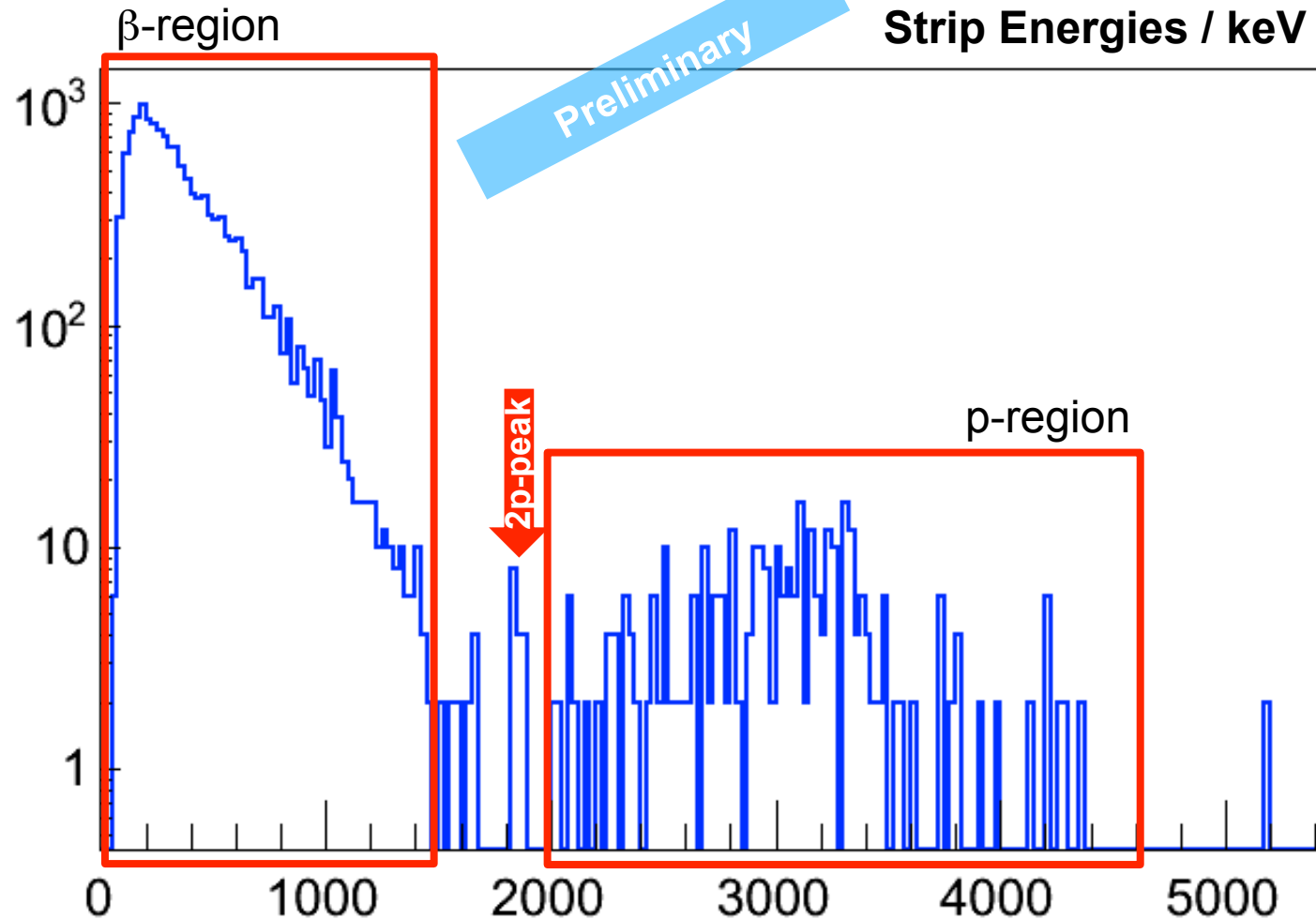



Further Nuclei: ^{94}Ag

Coincident γ -lines, fast component

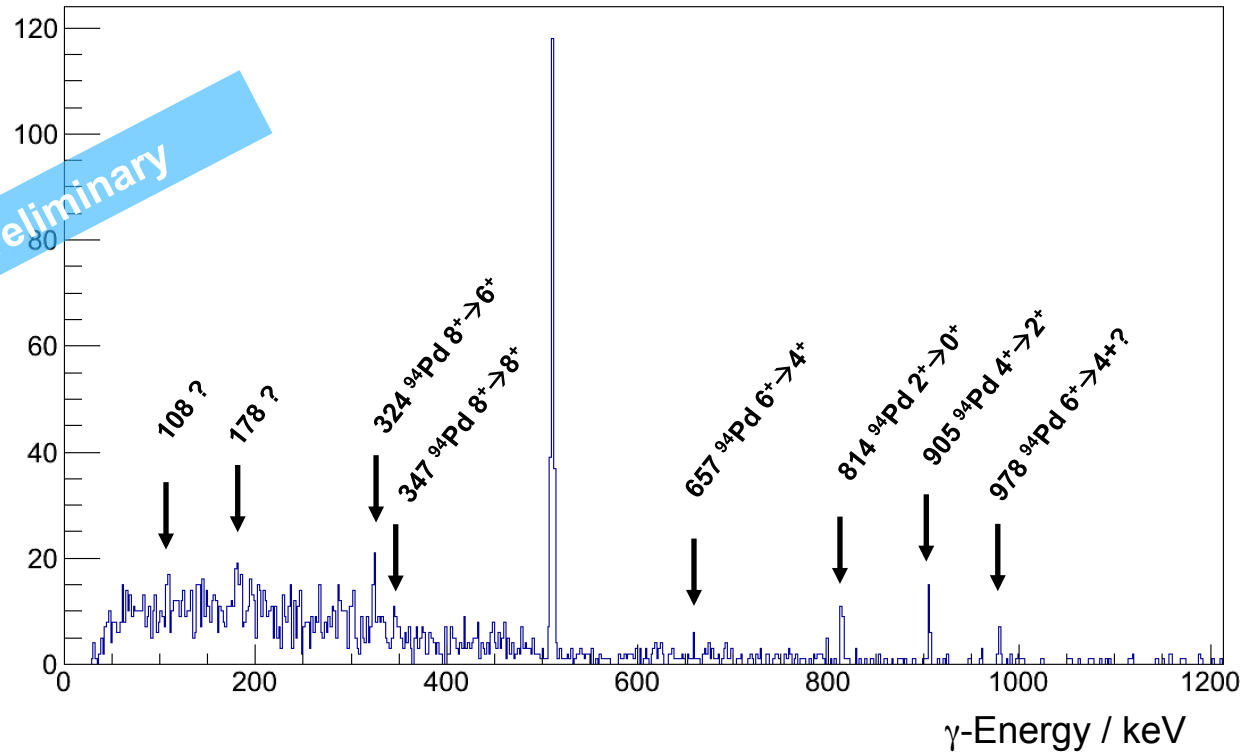
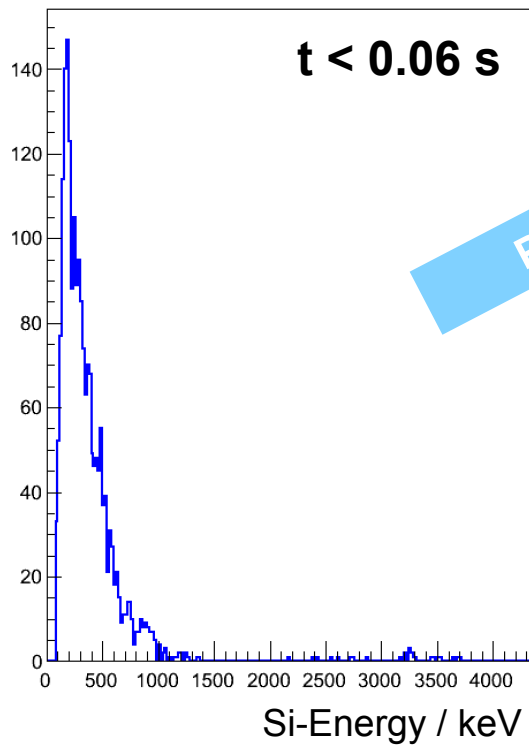

Further Nuclei: ^{94}Ag

Coincident γ -lines, slow component

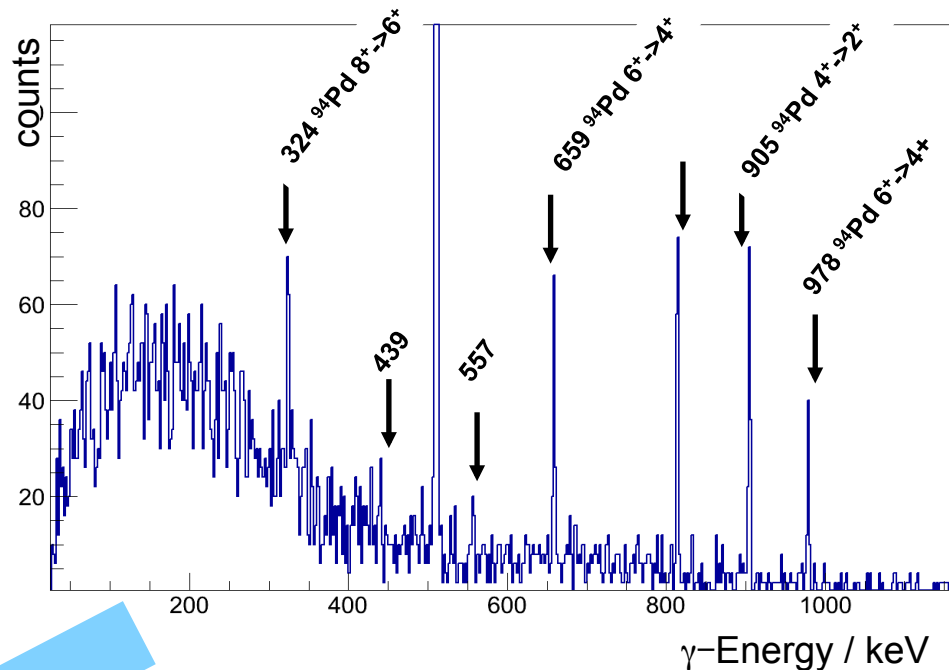
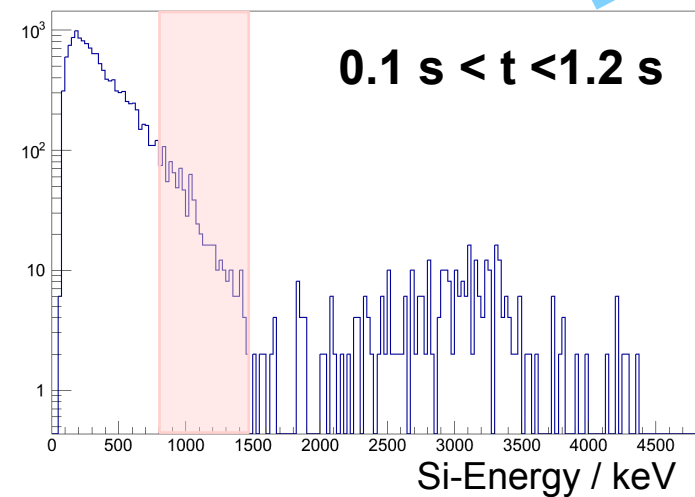
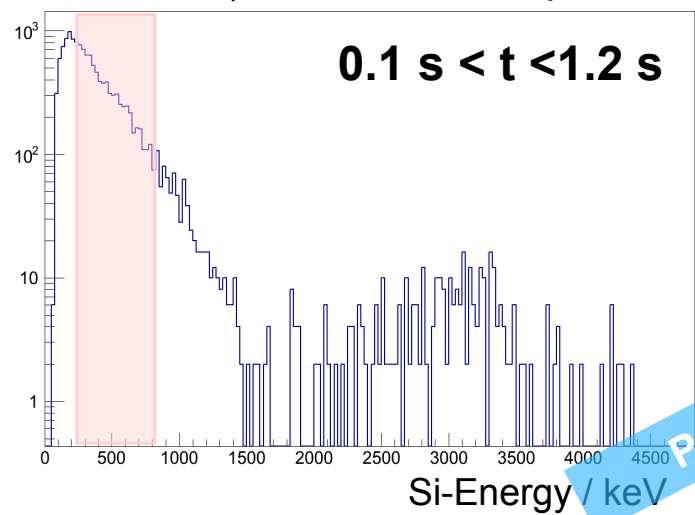

Preliminary

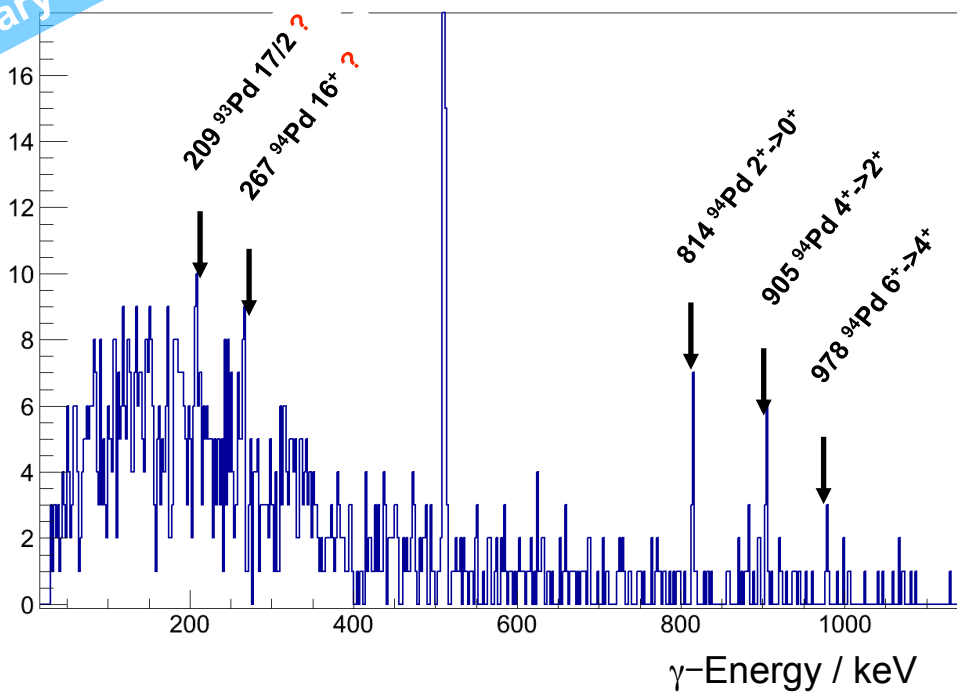

Further Nuclei: ^{94}Ag

Coincident γ -lines, slow component

$0.1 \text{ s} < t < 1.2 \text{ s}$

Preliminary

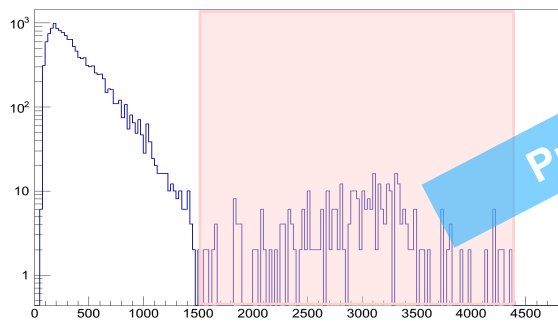

Si-Energy / keV

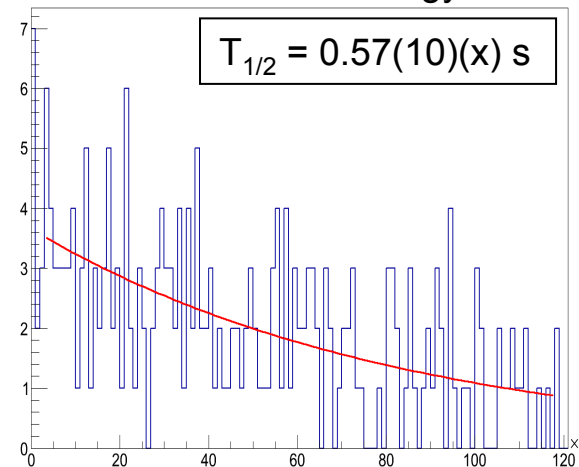

Time / 10 ns

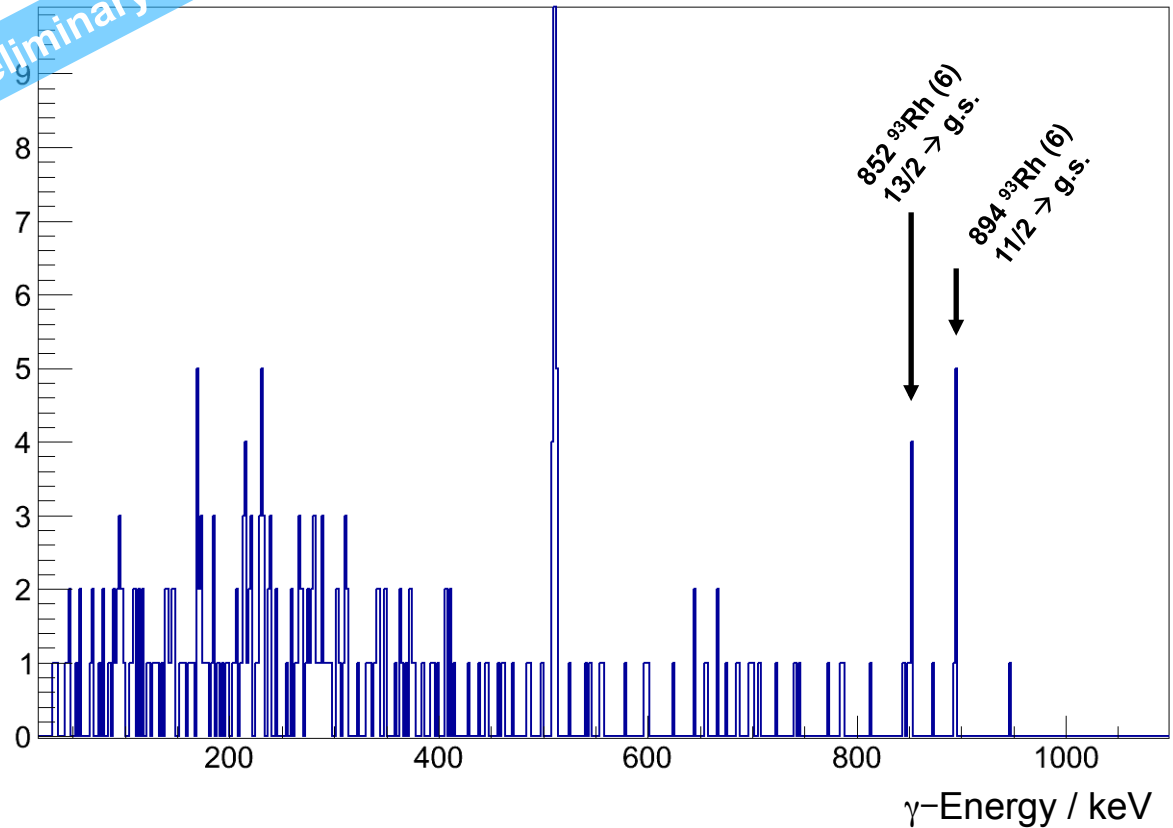



Further Nuclei: ^{94}Ag – Hint for 2p-decay

Event-by-event analysis

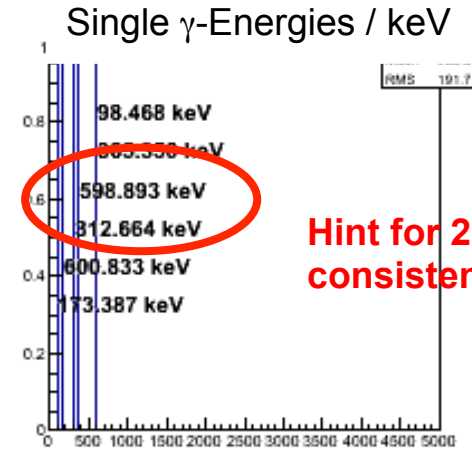
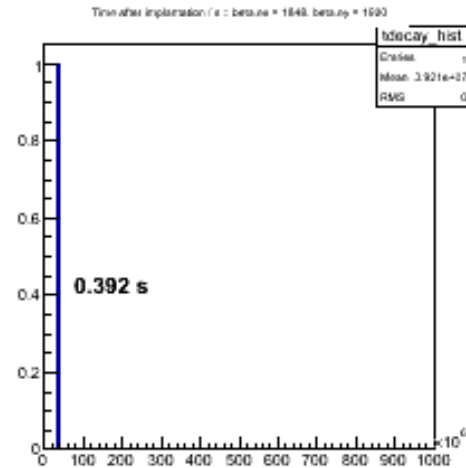
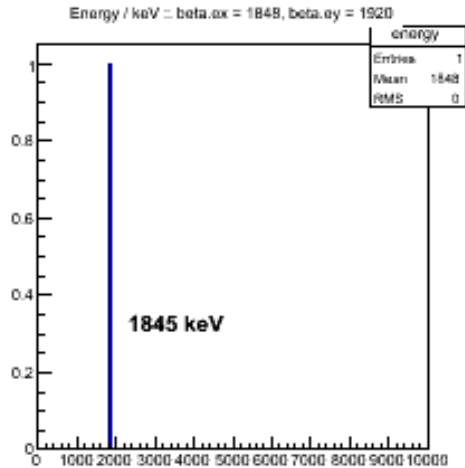

Hint for 2p decay,
consistent with [1]

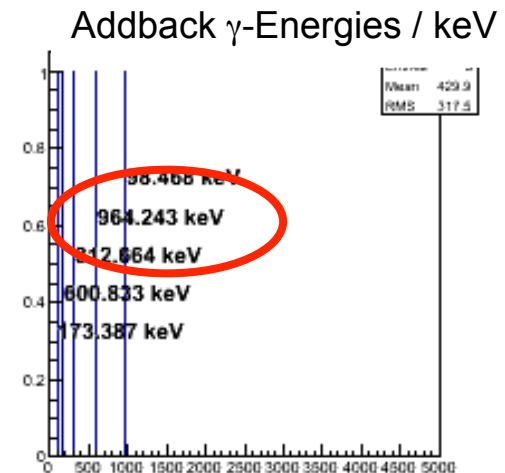
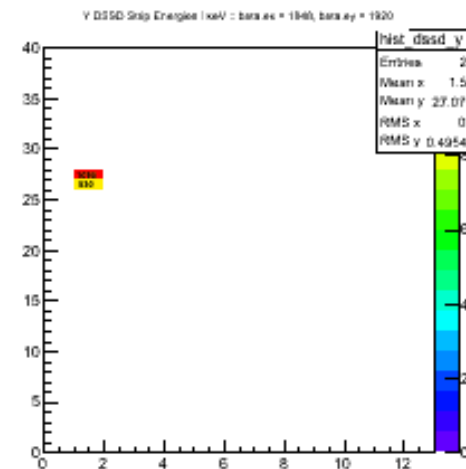
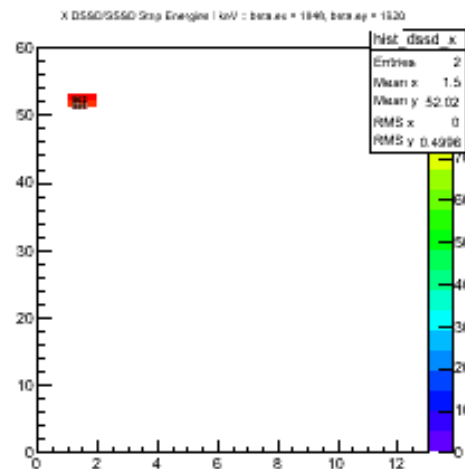

[1] Phys. Rev. C **76**, 011304(R) (2007)



Further Nuclei⁹⁴Ag – Hint for 2p-decay

2p decay: event-by-event analysis

Pixel energy / keV	time / ms	γ -energies crystal / keV	γ -energies cluster addback / keV
1845	392	98, 365, 599 , 313, 601, 173	98, 964 , 313, 601, 173
1885	984	787	787
1885	673	104, 147	104, 147
1845	666	274, 349 , 740	274, 349 , 740
1865	591	283, 813	1096
1855	538	166, 349	515
1895	213	79, 184	79, 184
1845	483	----	----
1835	810	----	----

Further Nuclei: ^{94}Ag – Hint for 2p-decay

Study of 2p-decay channels

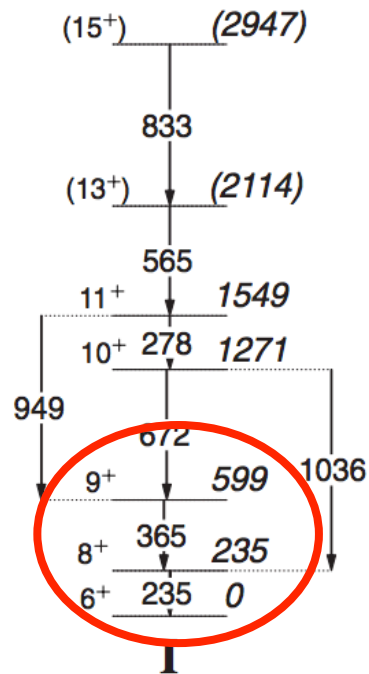

[1] O. L. Pechenaya, Phys. Rev. **C76**, 011304(R) (2007)

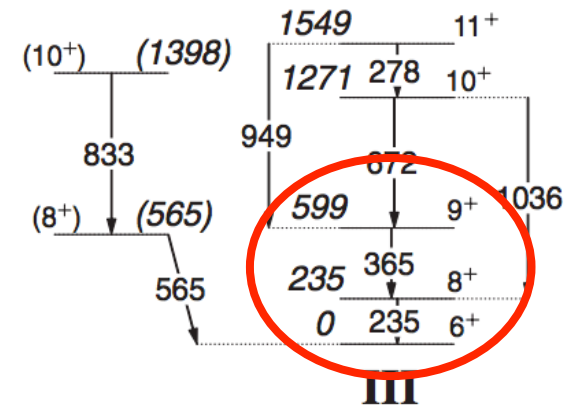
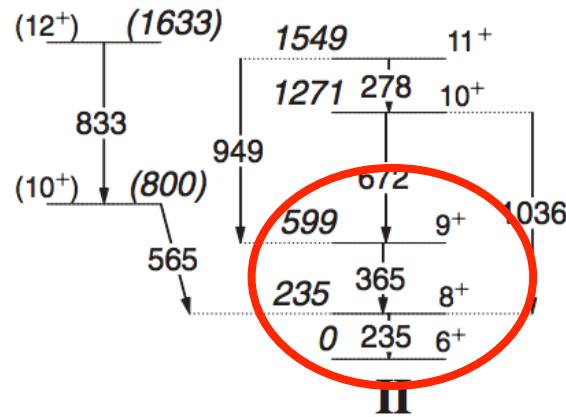

Each ruled out by a confidence level of at least 96%

This experiment: concerning ^{94}Ag statistics are too less for new conclusions. Another dedicated campagne is necessary.

Summary

Status of Analysis & Outlook

- About finalizing ^{100}Sn analysis (half-lives, $Q\beta$)
- Determined lifetimes of $N = Z - 1$ nuclei

- Obtained much better statistics
- Much information about neighboring nuclei and its structure

- Collaborators @ TRIUMF, Canada are working on the γ -spectroscopy of measured nuclei

- Great region to study the shell model and dig into β -delayed γ -spectroscopy

Collaboration

I appreciate work with and support from the EURICA RIBF09 collaboration, the RIKEN Nishina Center, the RIKEN IPA Program and the DFG Excellence Cluster “*Origin and Structure of the Universe*”.

Collaborators

M. Lewitowicz, R. Gernhäuser, R. Krücken, S. Nishimura, H. Sakurai, H. Baba, B. Blank, A. Blazhev, P. Boutachkov, F. Browne, I. Celikovic, P. Doornenbal, T. Faestermann, Y. Fang, G. de France, N. Goel, M. Gorska, S. Ilieva, T. Isobe, A. Jungclaus, G. D. Kim, Y.-K. Kim, I. Kojouharov, M. Kowalska, D. Lubos, N. Kurz, Z. Li, G. Lorusso, K. Moschner, I. Nishizuka, J. Park, Z. Patel, M. M. Rajabali, S. Rice, H. Schaffner, L. Sinclair, P.-A. Söderström, K. Steiger, T. Sumikama, H. Watanabe, Z. Wang, J. Wu, and Z. Y. Xu

Institutions

Physik Department E12, Technische Universität München; RIKEN Nishina Center; TRIUMF; GANIL; Department of Physics, University of Tokyo; CENBG, Institut für Kernphysik; Universität zu Köln; GSI Darmstadt; School of Comp., Eng. and Maths., Brighton University; Department of Physics, Osaka University; Institut für Kernphysik; TU Darmstadt; IES CSIS; Institute for Basic Science; CERN, School of Physics, Peking University; Department of Physics, Tohoku University; Department of Physics, Surrey University; Department of Physics, University of York; Department of Physics, Beihang University

Thank you for listening!

References

- [1] H. Suzuki et al. Nucl. Inst. and Meth. in Physics B 317 (2013) 756–768
- [2] I. Celikovic PhD thesis, Université de Caen Basse-Normandie (2014)
- [3] K. Straub PhD thesis , Technische Universität München (2011)
- [4] A. Blazhev et al., Phys. Rec. C **69**, 064304 (2004)
- [5] A. Blazhev et al., JoP: Conf. Series **205** (2010) 012035
- [6] C. Hinke, *Nature* **486** (2012) 341
- [7] T. Faestermann et al., Prog. Part. Nucl. Phys. **69** (2013) 85
- [8] A. Stolz, PhD-thesis *TUM* (2001)