

# Scintillation of liquid argon and liquid argon-xenon mixtures

Andreas Ulrich

andreas.ulrich@ph.tum.de



Scintillation of liquid argon (O<sub>2</sub> impurity)

This presentation is based on the PhD thesis of

Thomas Heindl  
Martin Hofmann  
Alexander Neumeier  
Andreas Himpsl



Cluster Workshop  
Garching, May, June 2016



## Content

Scintillation of rare gases

Detector concepts

Emission spectrum of pure liquid argon

Ultraviolet and infrared emission from liquid argon xenon mixtures

Particle identification observing UV and IR ?



## The scintillation of rare gases:

- Separated atoms
- Collisional excitation
- Collisional ionization
- Optical transitions on „atomic side“
- Collisional de-excitation
- Molecule formation from excited states
- Vibr. Relaxation of Molecules
- Pre-dissociation
- Radiation trapping
- Optical transitions to the repulsive ground state

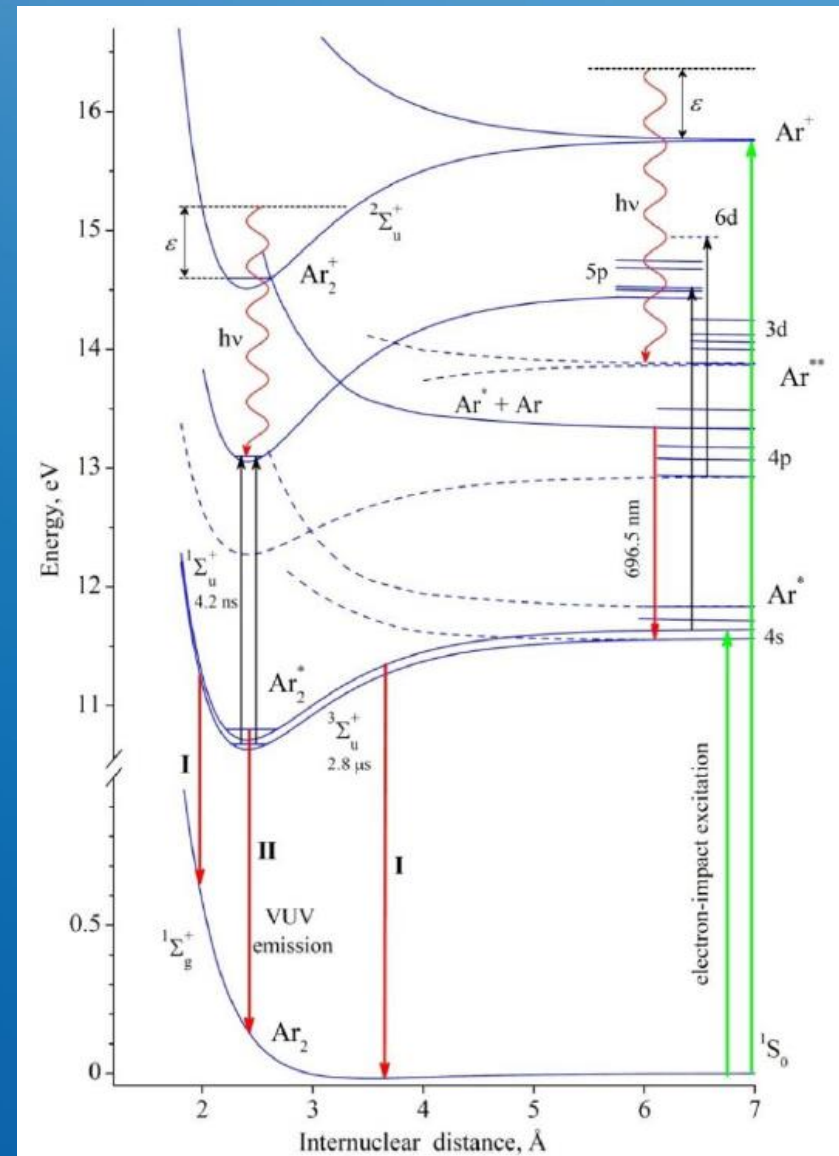

## Overview: Light emission from pure rare gases

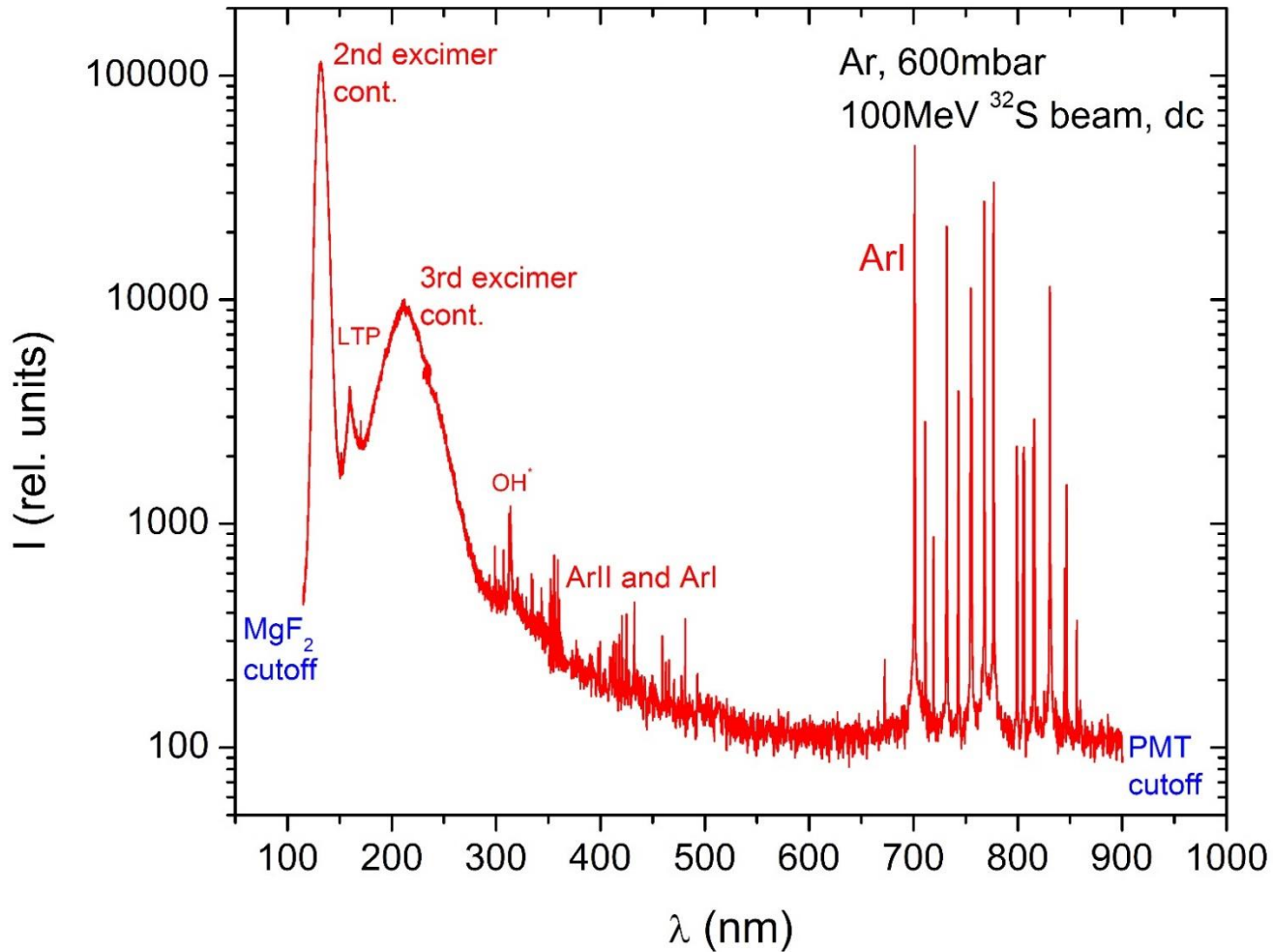

# Excimer emission: ground state transitions

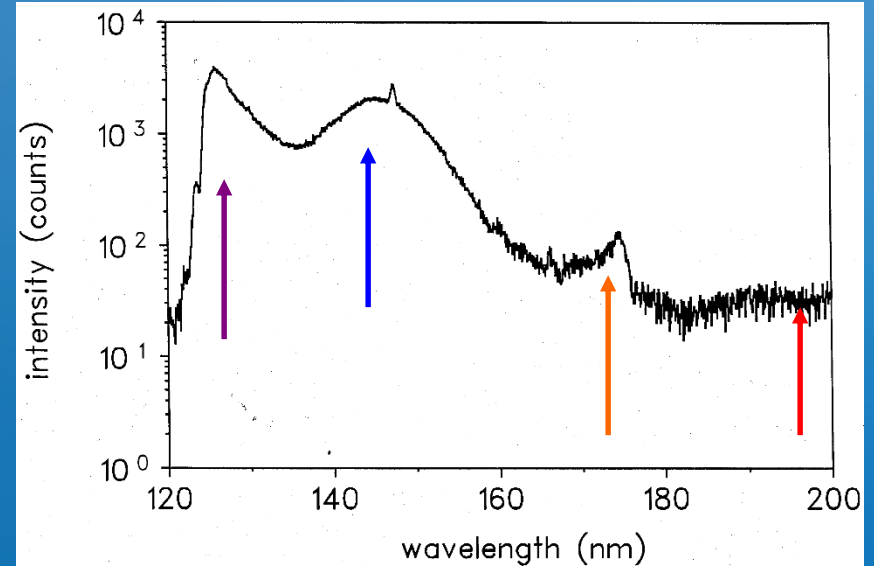
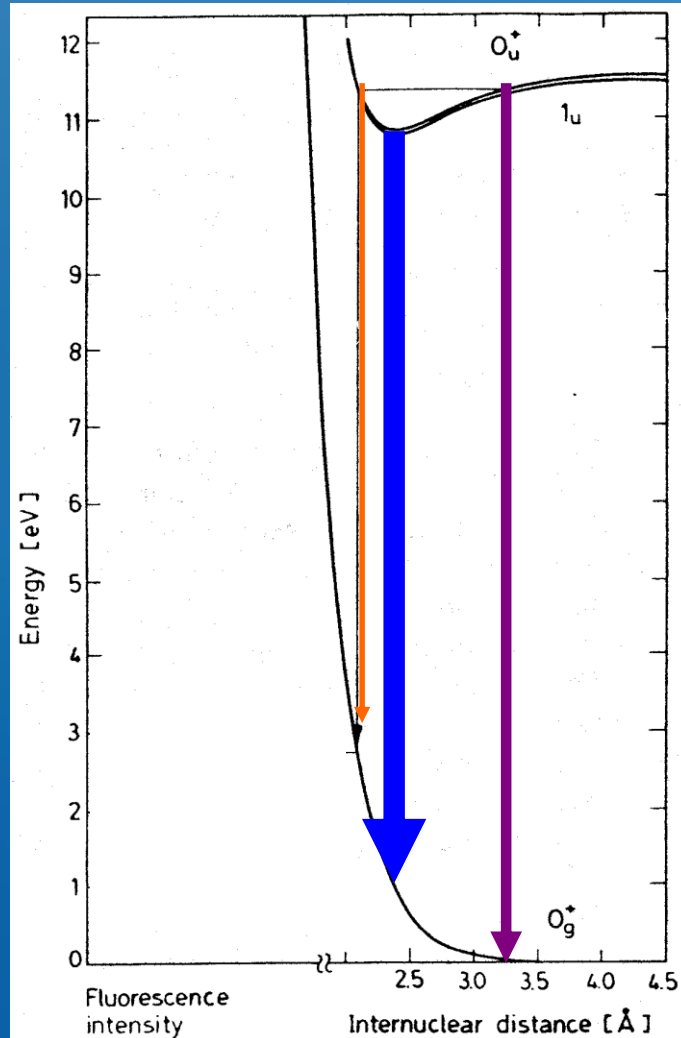

Kr 100 mbar

- „First continuum“
- „Second continuum“
- „Classical left turning point“
- „Third continuum“

... $ns^2 np^6$  exception: He

VUV emission from rare gases with e-beam excitation

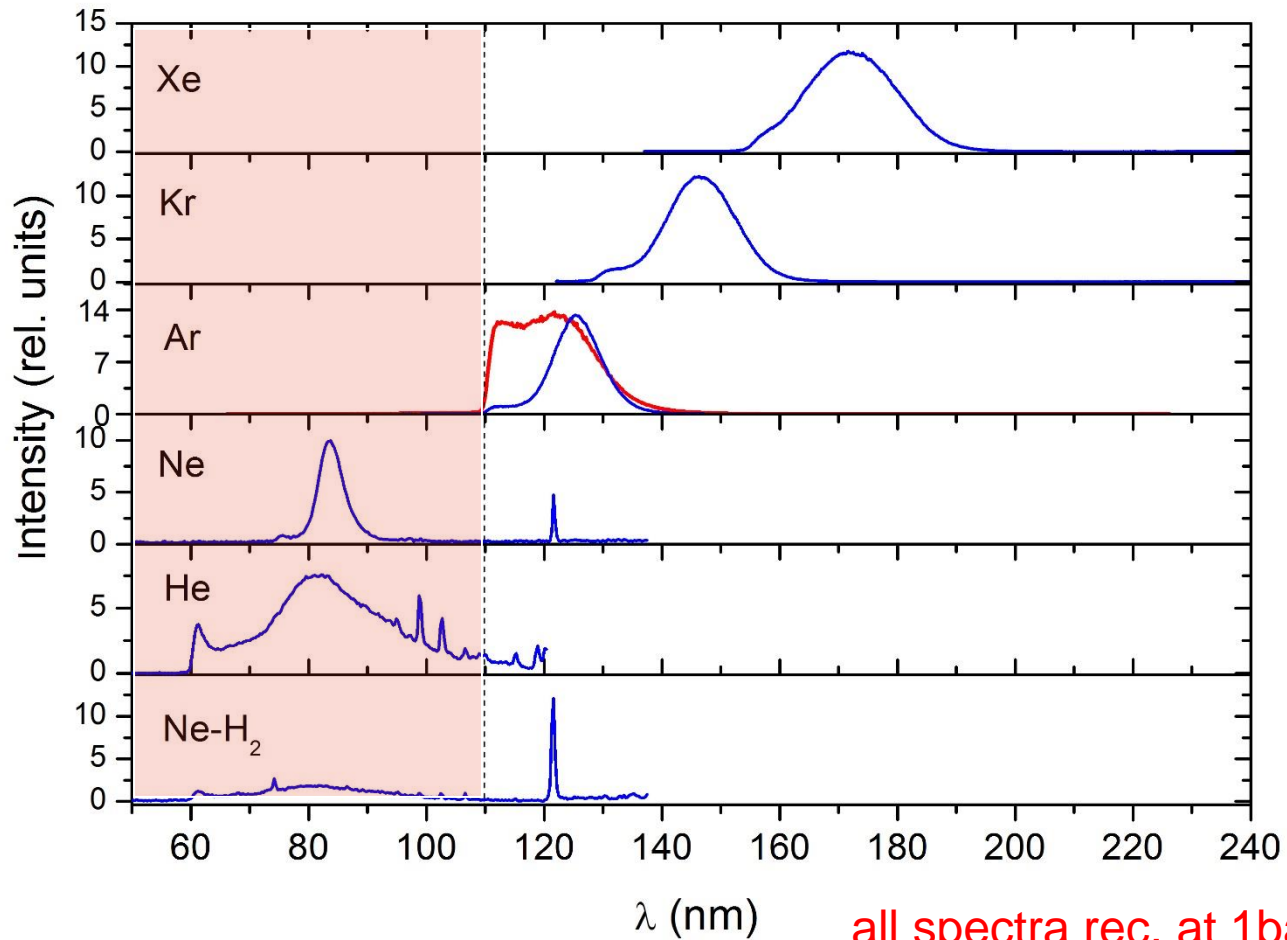

## Efficiency of the excimer emission from pure rare gases

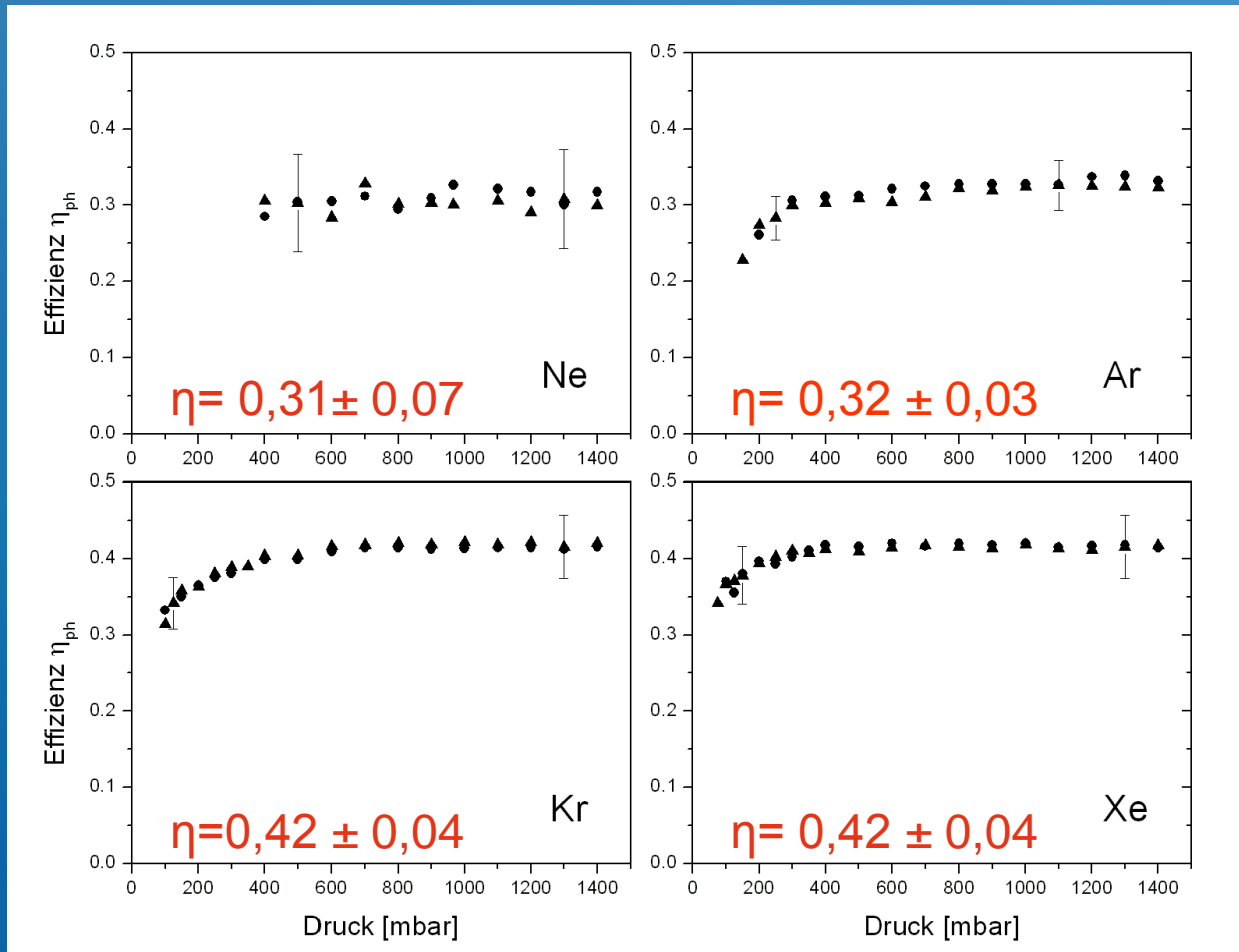

Diploma thesis: Thomas Heindl, JOURNAL OF APPLIED PHYSICS **103**, 103301 (2008)



# Application for Vacuum Ultraviolet Light Sources:

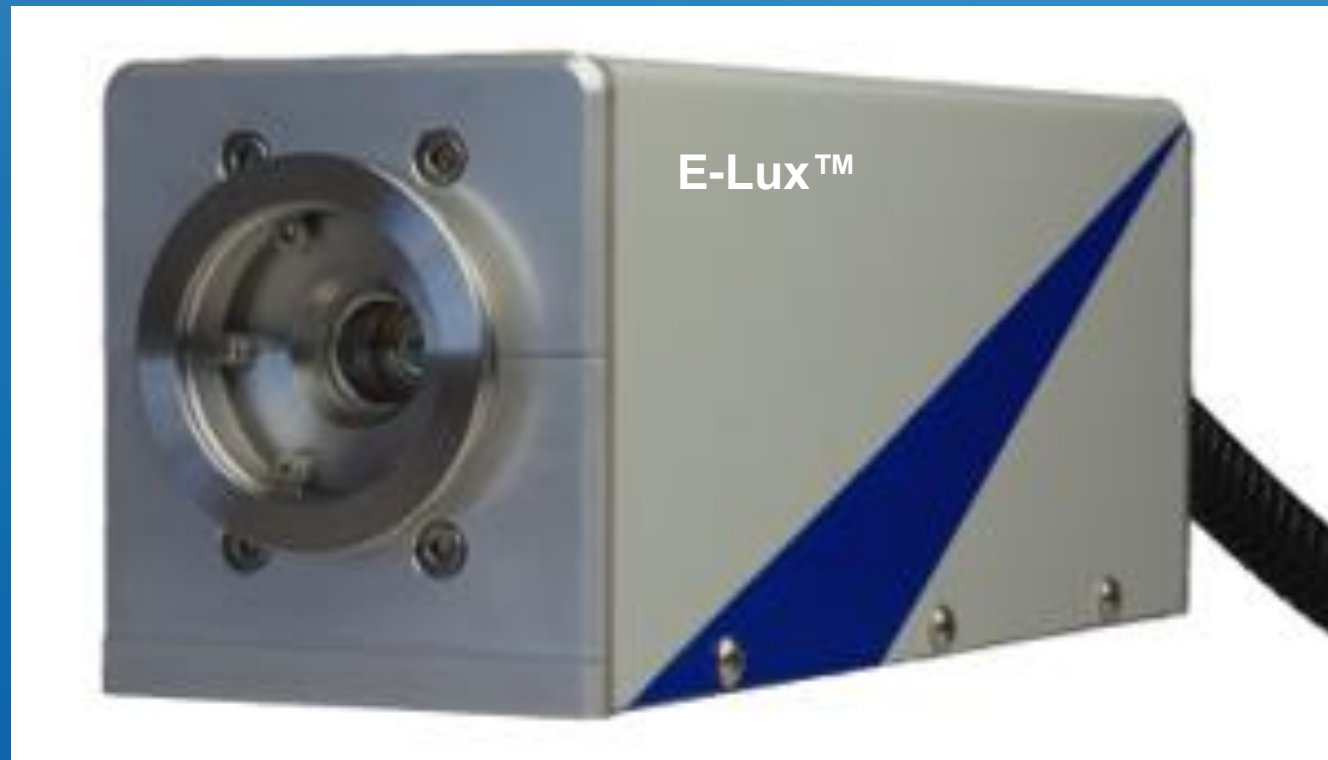
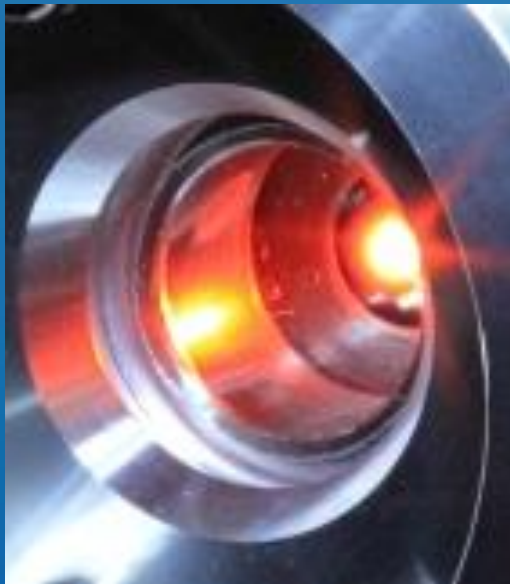



## Third continuum of argon: dominant emission at early times following pulsed excitation

Optics Communications 173 (2000) 233–245

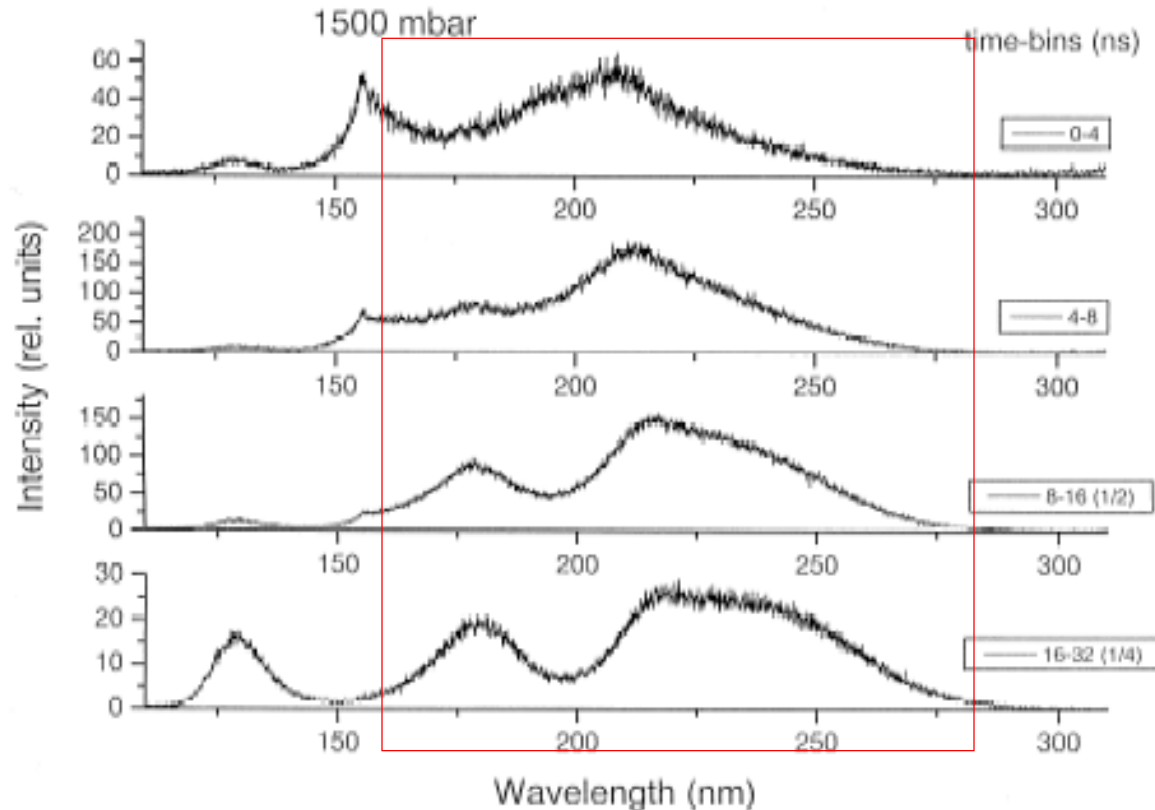

Fig. 4. Wavelength spectra of 1500 mbar Ar from 110 nm to 310 nm, excited by a 2 ns 100 MeV  $^{32}\text{S}$  beam in the time windows 0–4 ns, 4–8 ns, 8–16 ns, and 16–32 ns after excitation are shown. The intensity scale of all time windows has been normalized to a 4 ns time interval.

## Link to liquid rare-gas detector-physics:

- The VUV emission from liquid and solid rare gases is very similar to the gas phase
- If also the third continuum appears in liquid rare gases and the light detection is wavelength integrated (wavelength shifter!) then the third continuum will have a strong influence of the time signal!



# Liquid rare gas detector concepts:

## a) Single phase

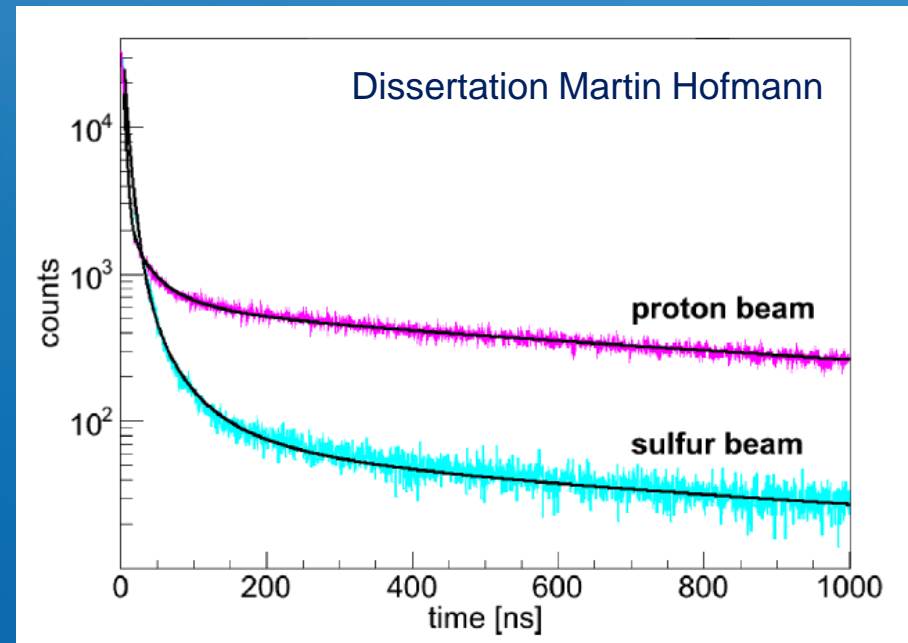
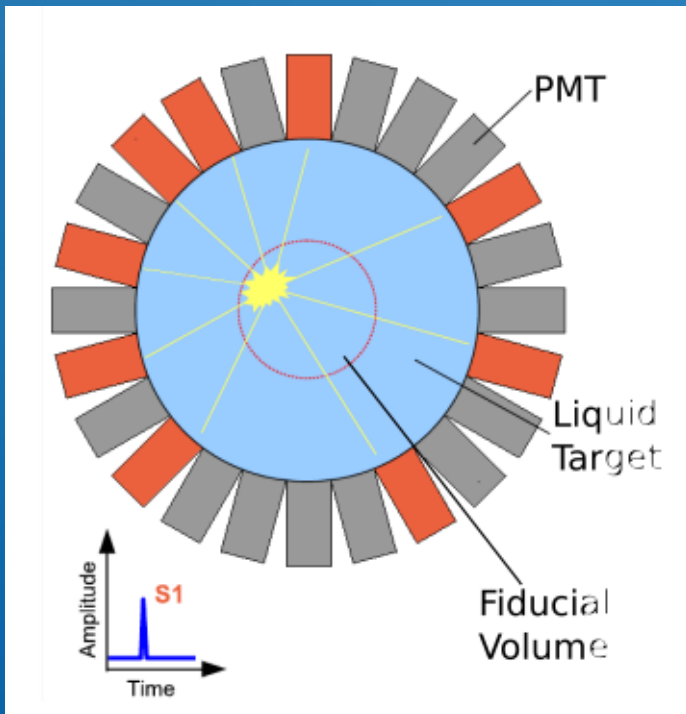

## Particle identification via time signal

M. Schumann. "Dark Matter Search with liquid Noble Gases". arXiv:1206.2169v1 [astro-ph.IM], 2012

## b) Two phase detectors

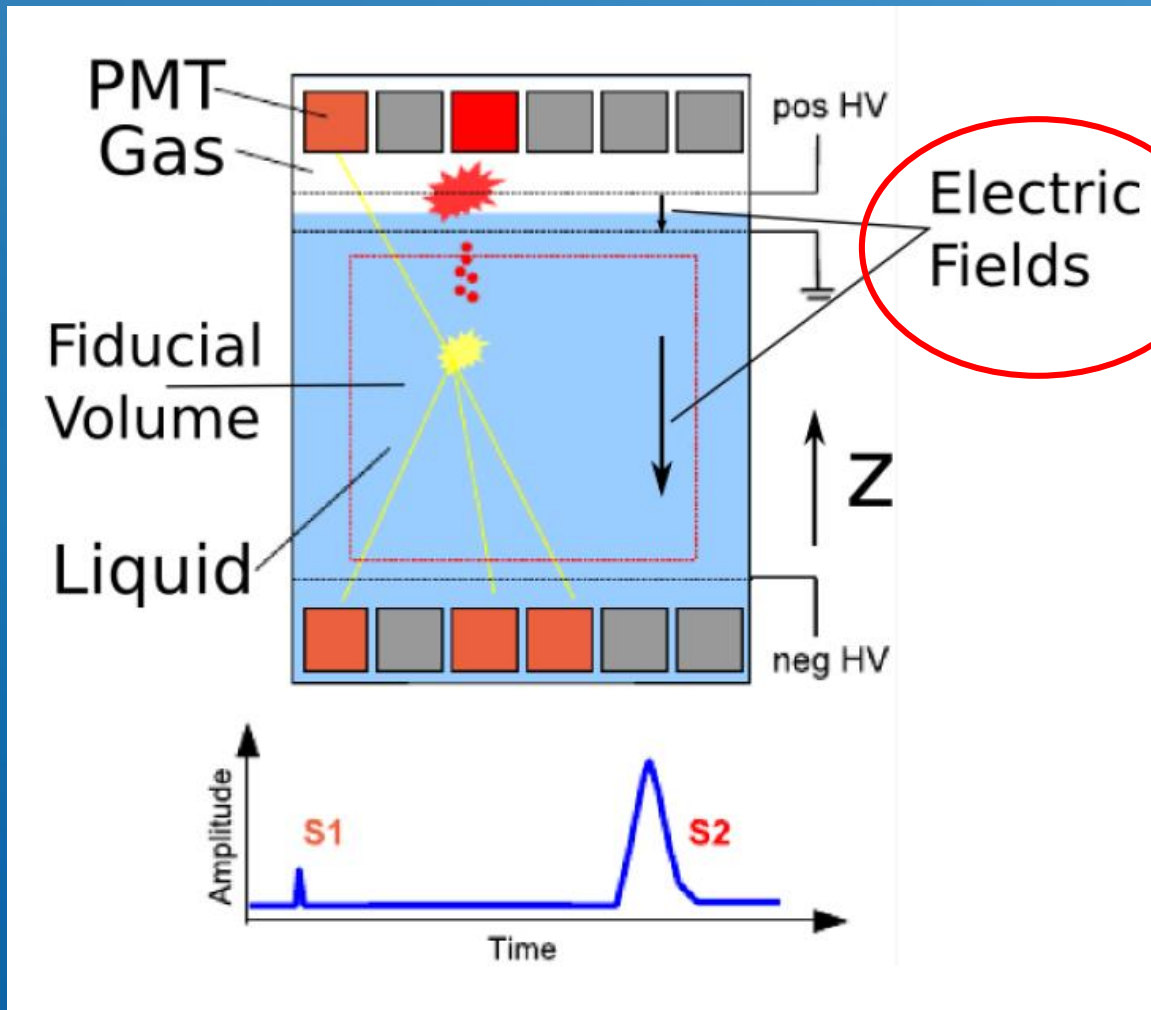

Can be a problem in large detectors!

M. Schumann. "Dark Matter Search with liquid Noble Gases". arXiv:1206.2169v1 [astro-ph.IM], 2012

# Spectroscopy of liquid rare gases using low energy electron beam excitation

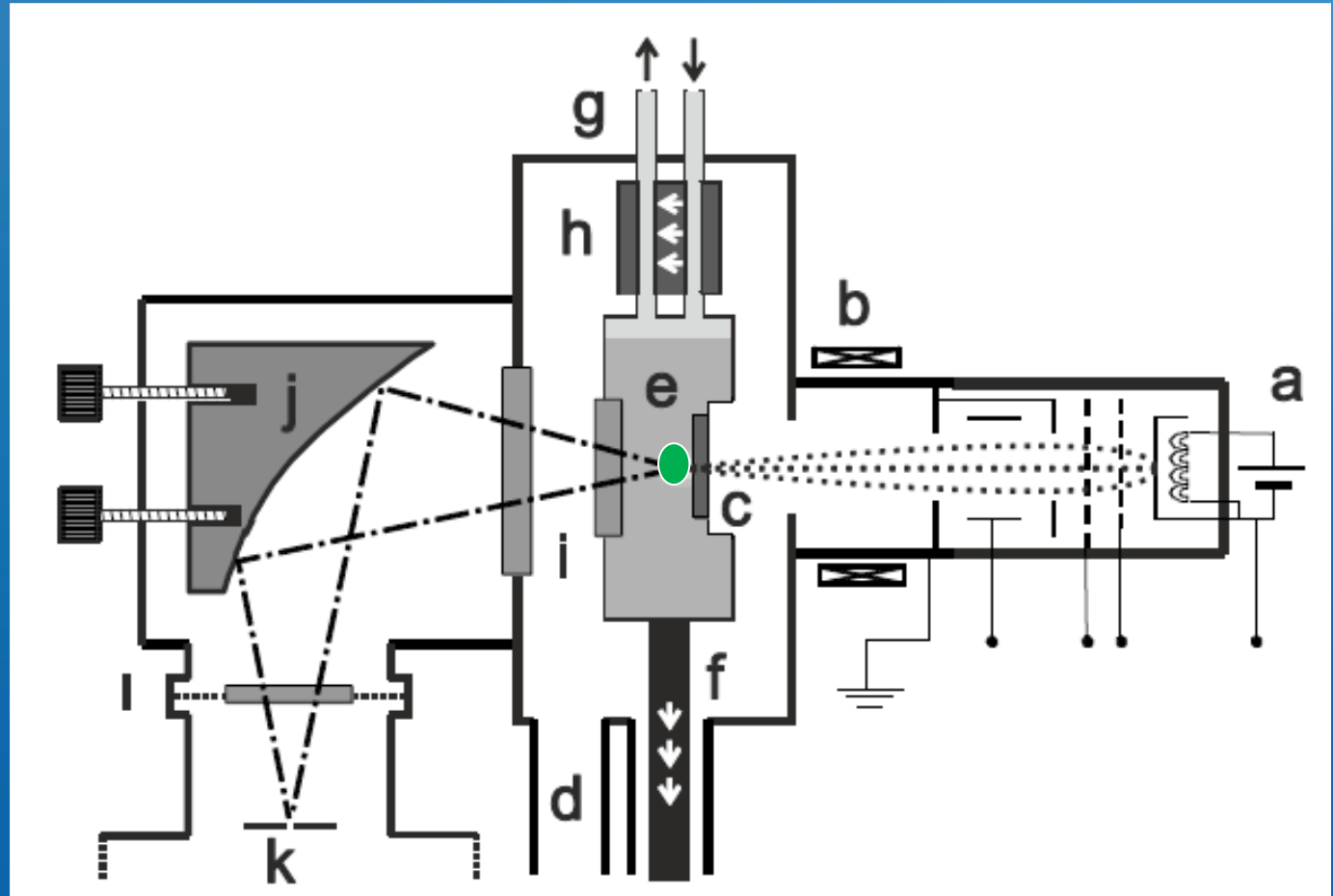

## Detail of the technology

300nm ceramic membranes as entrance windows for the beam

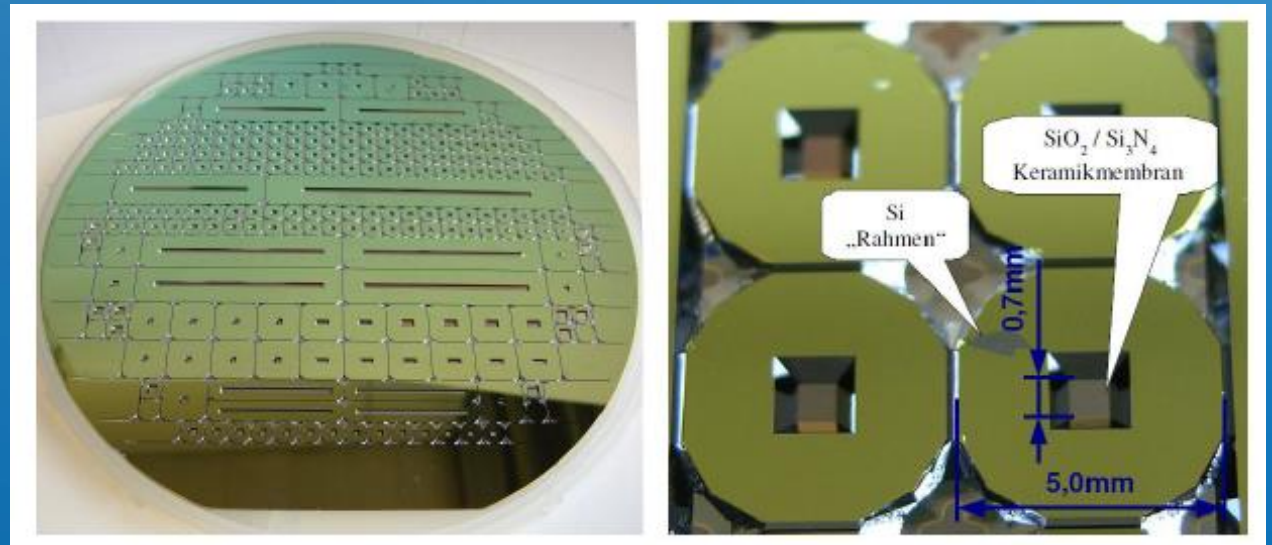
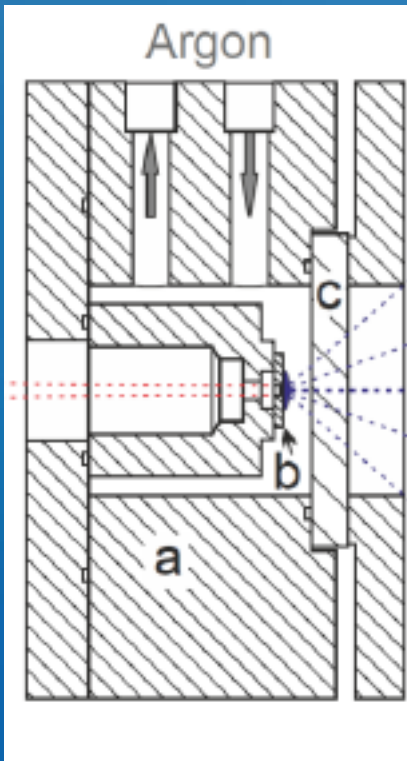

# Phase diagram of argon

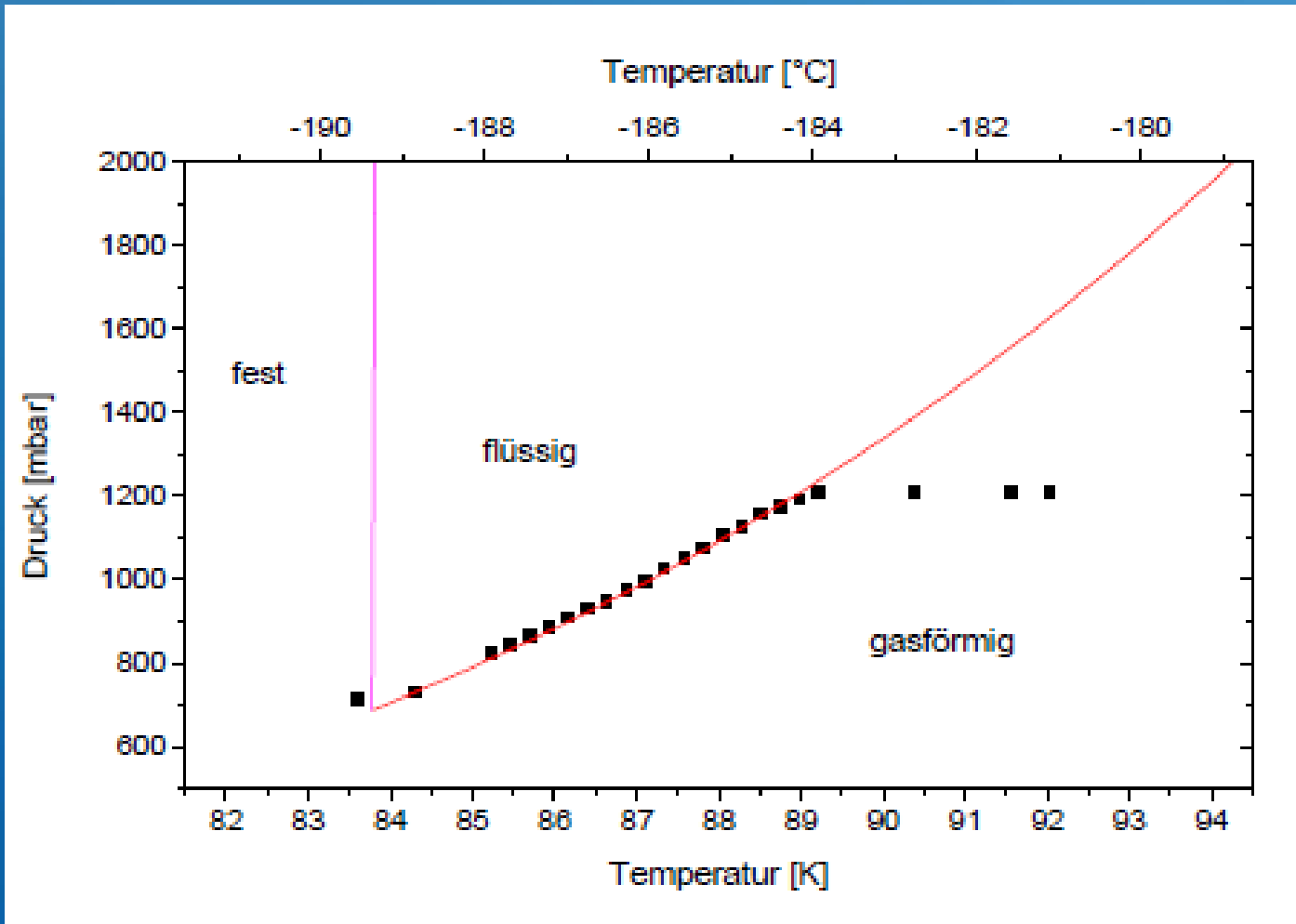

# Emission spectrum of pure liquid argon

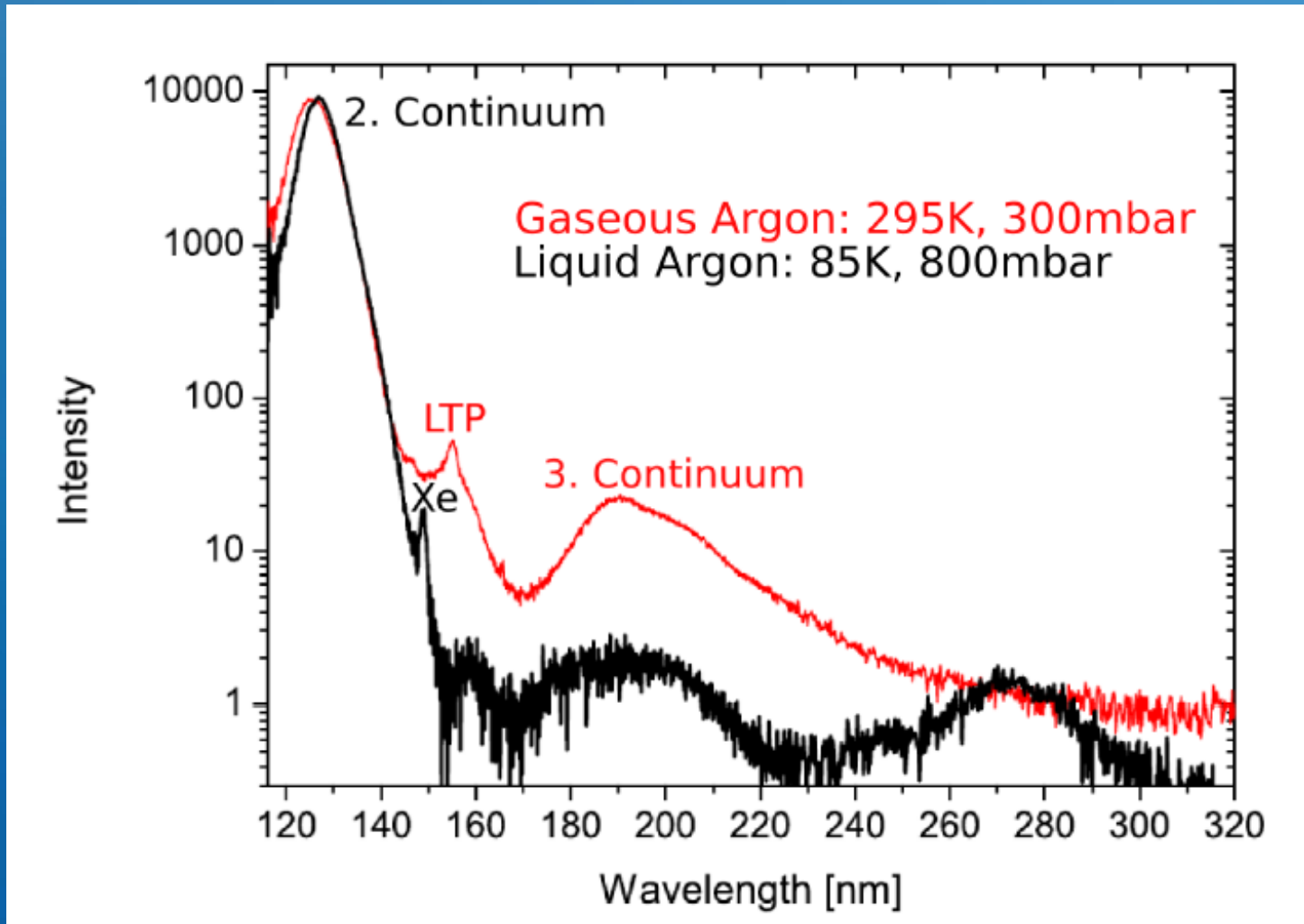

An attempt for an assignment of emission features at longer wavelengths:

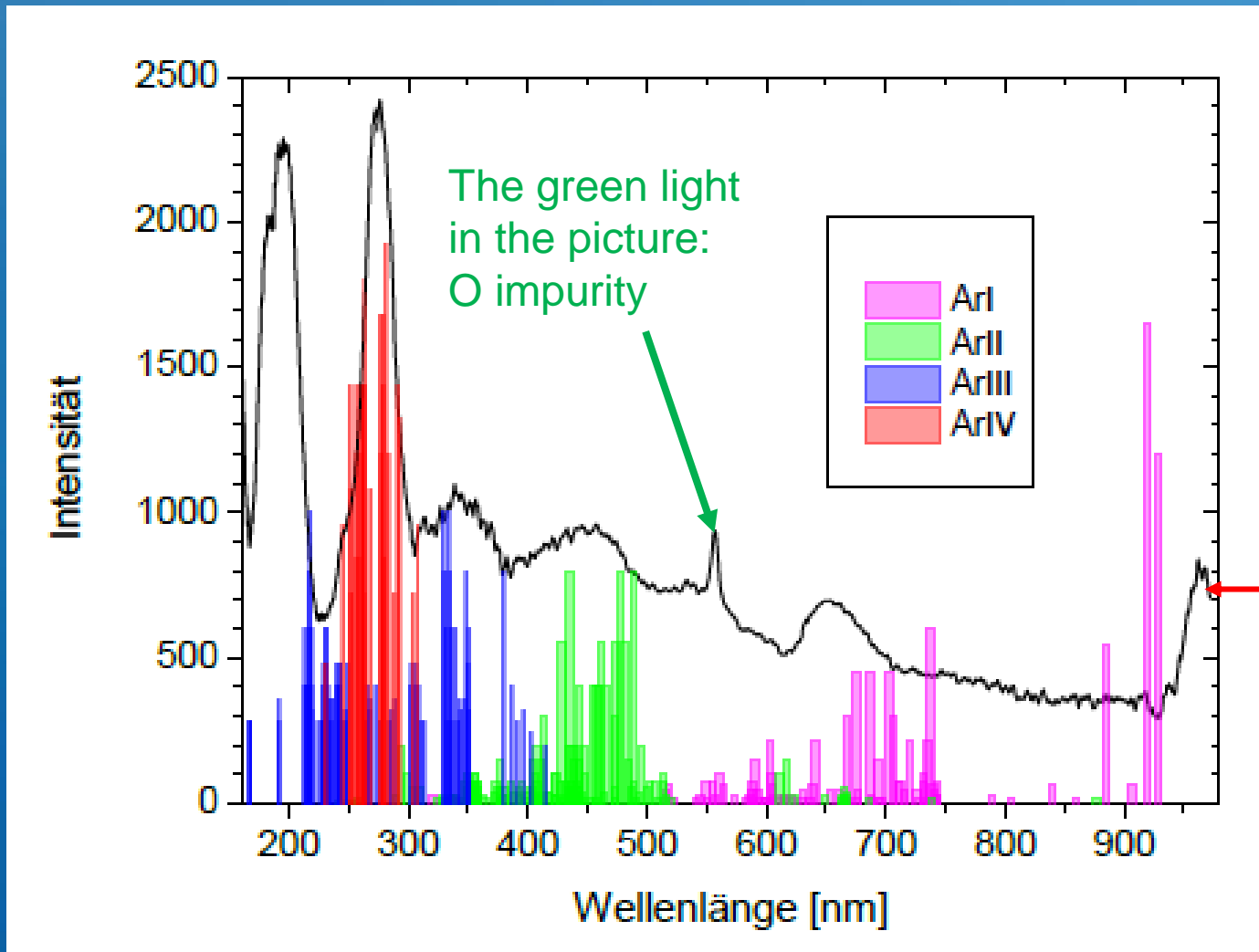

Emission in the near IR ?

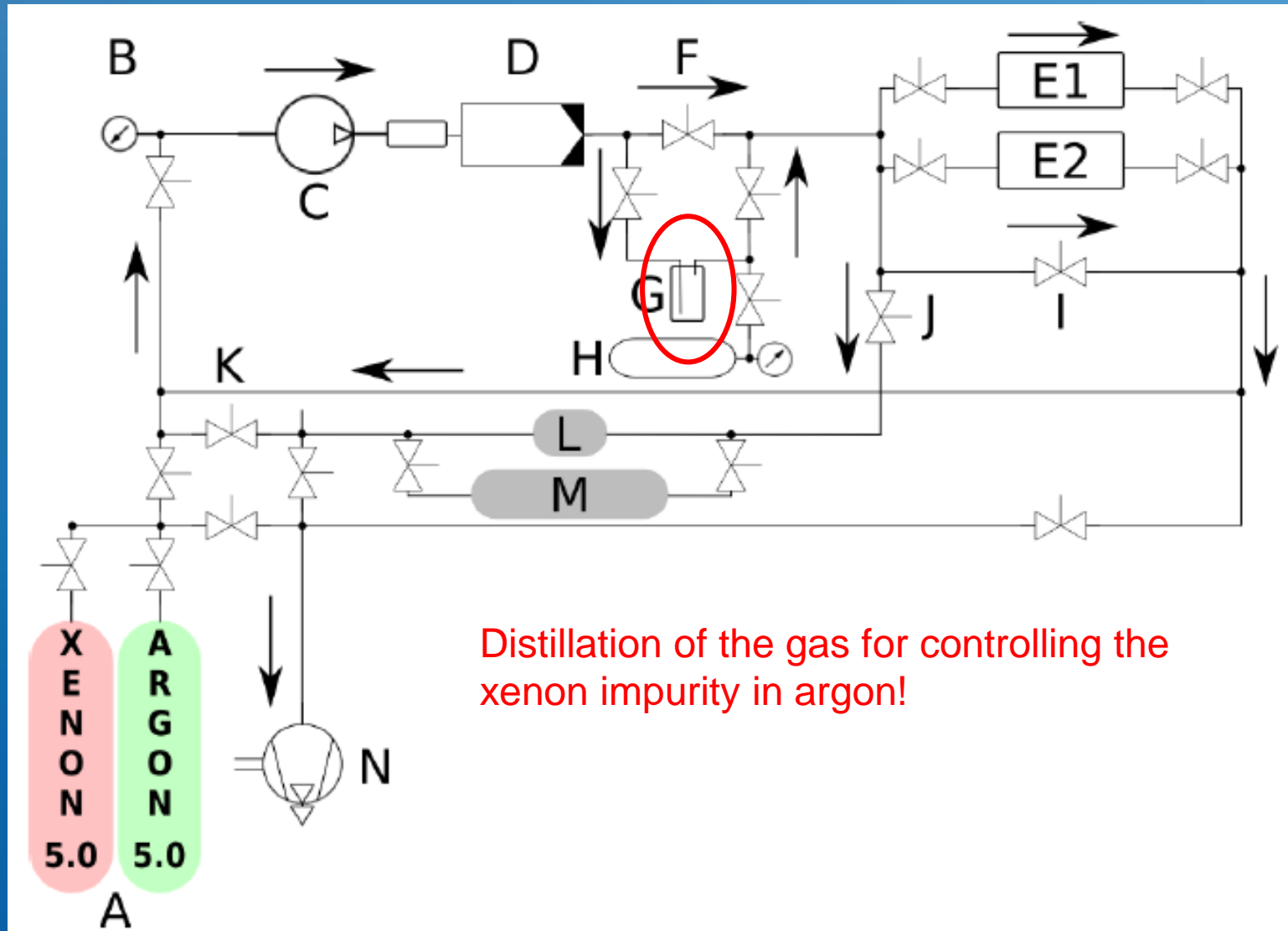

A vis-IR emission spectrum of highly purified argon (below) and an Ar-Xe mixture

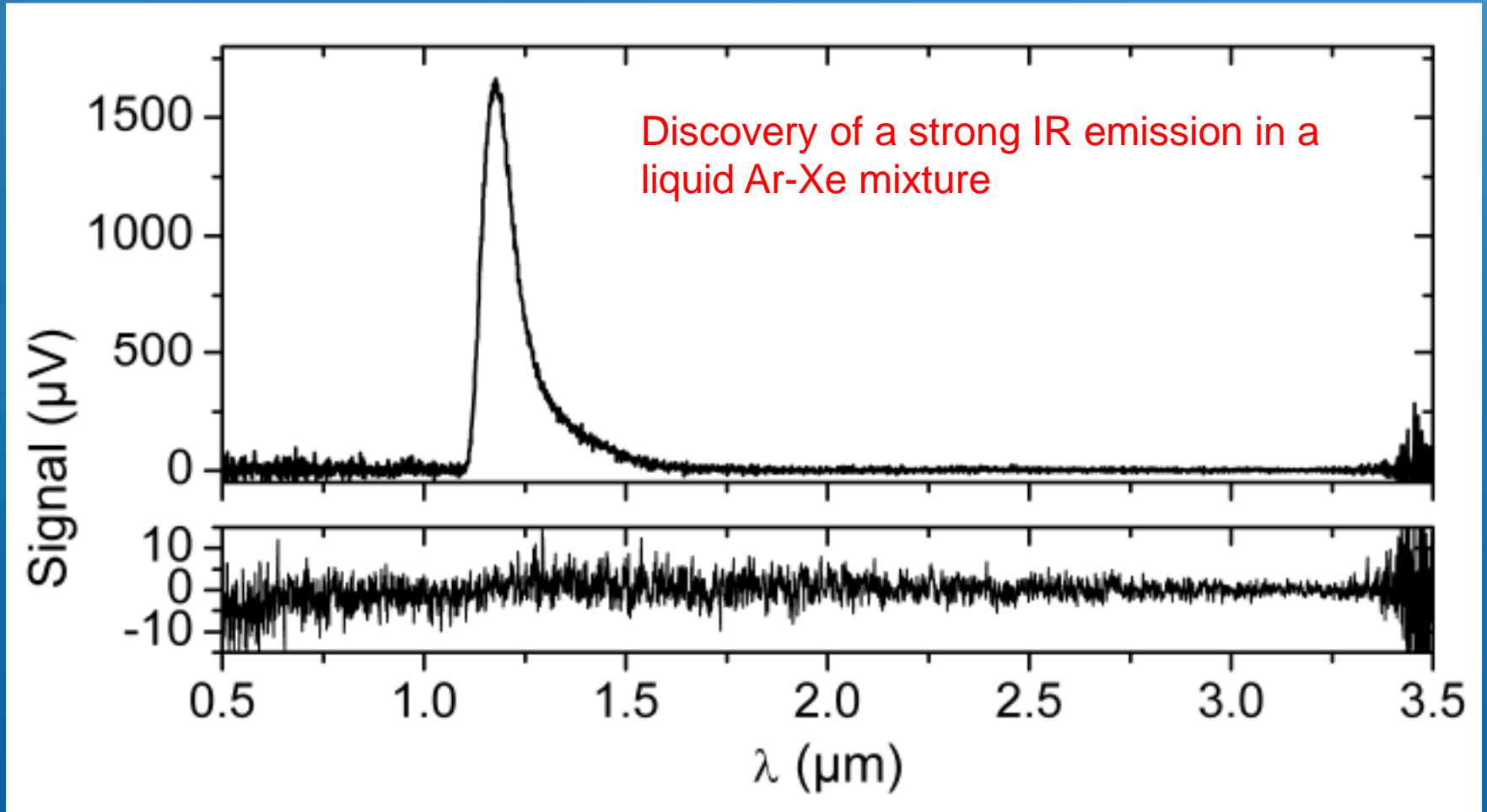

# Comparison of a wide spectral range of liquid Ar and Ar-Xe (10ppm)

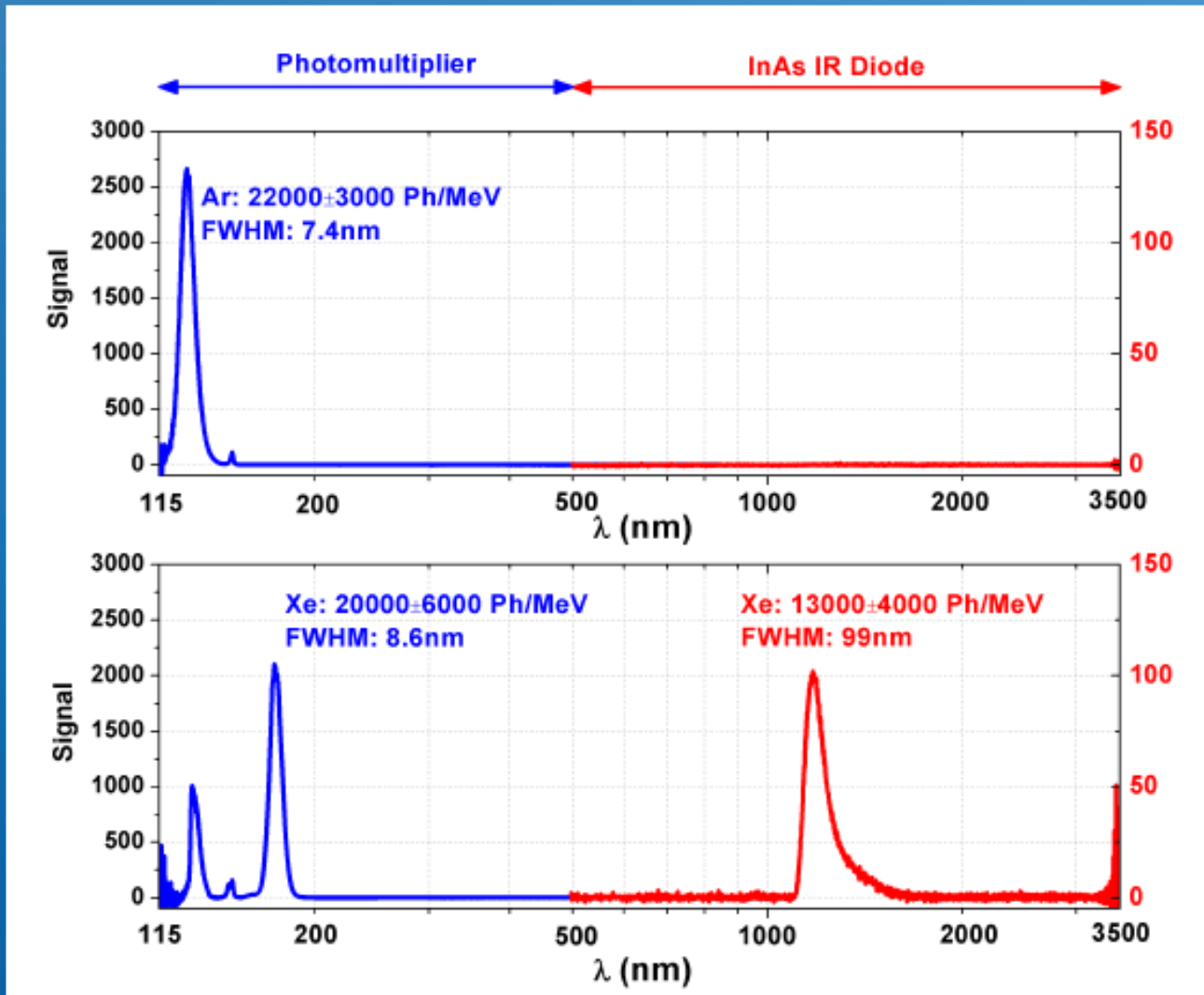

# Optimization of the xenon content

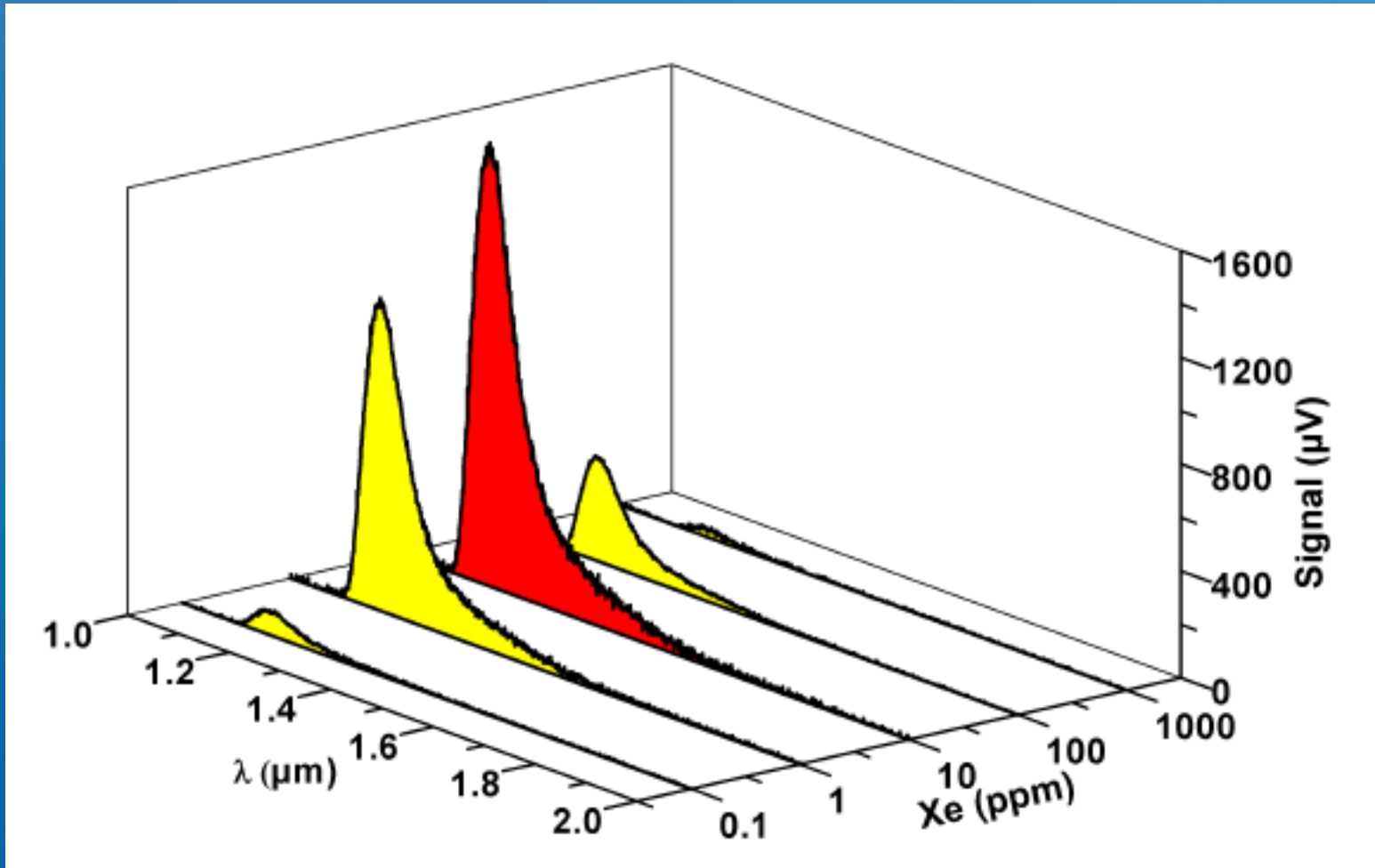

# What happens in the vacuum ultraviolet:

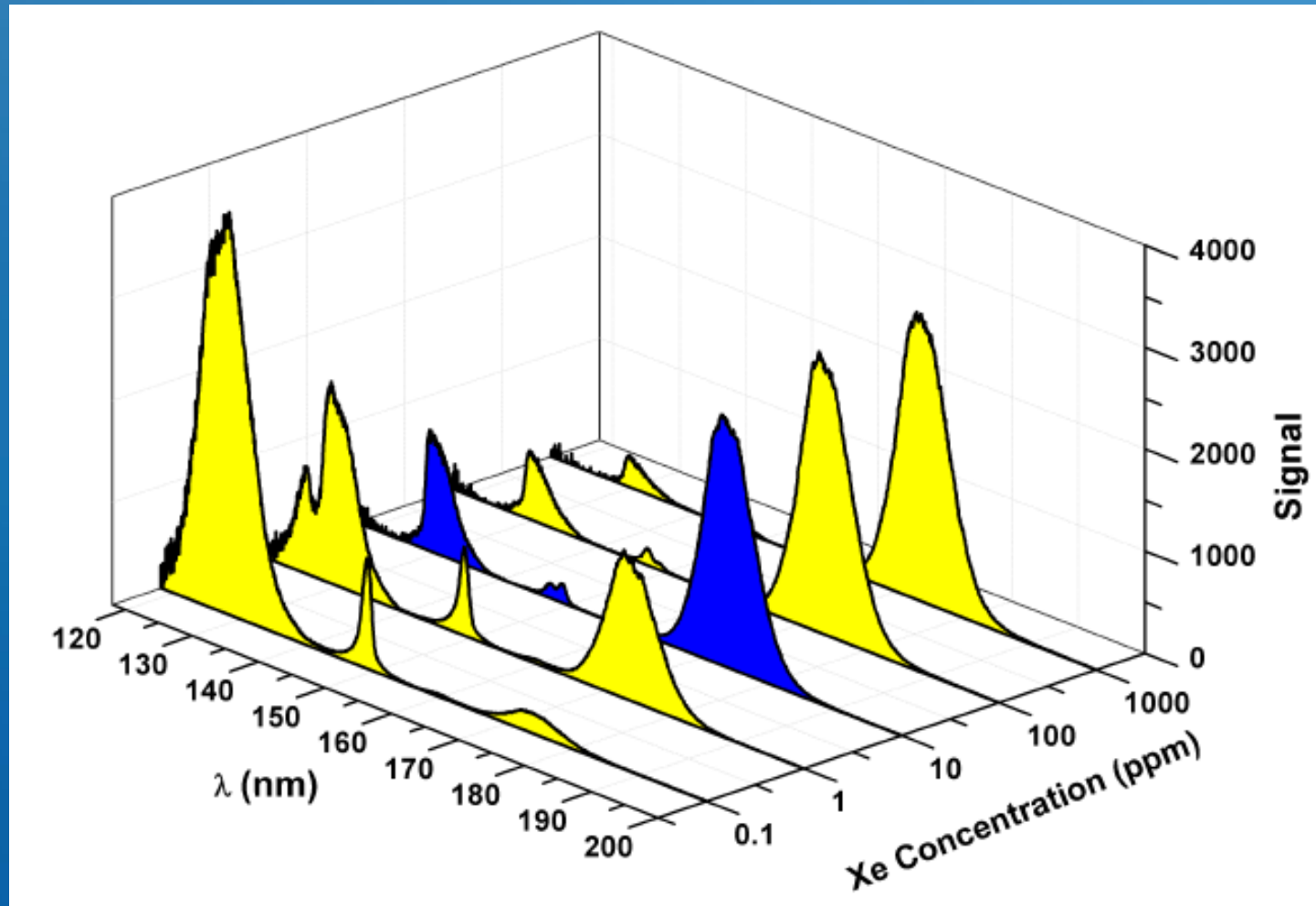

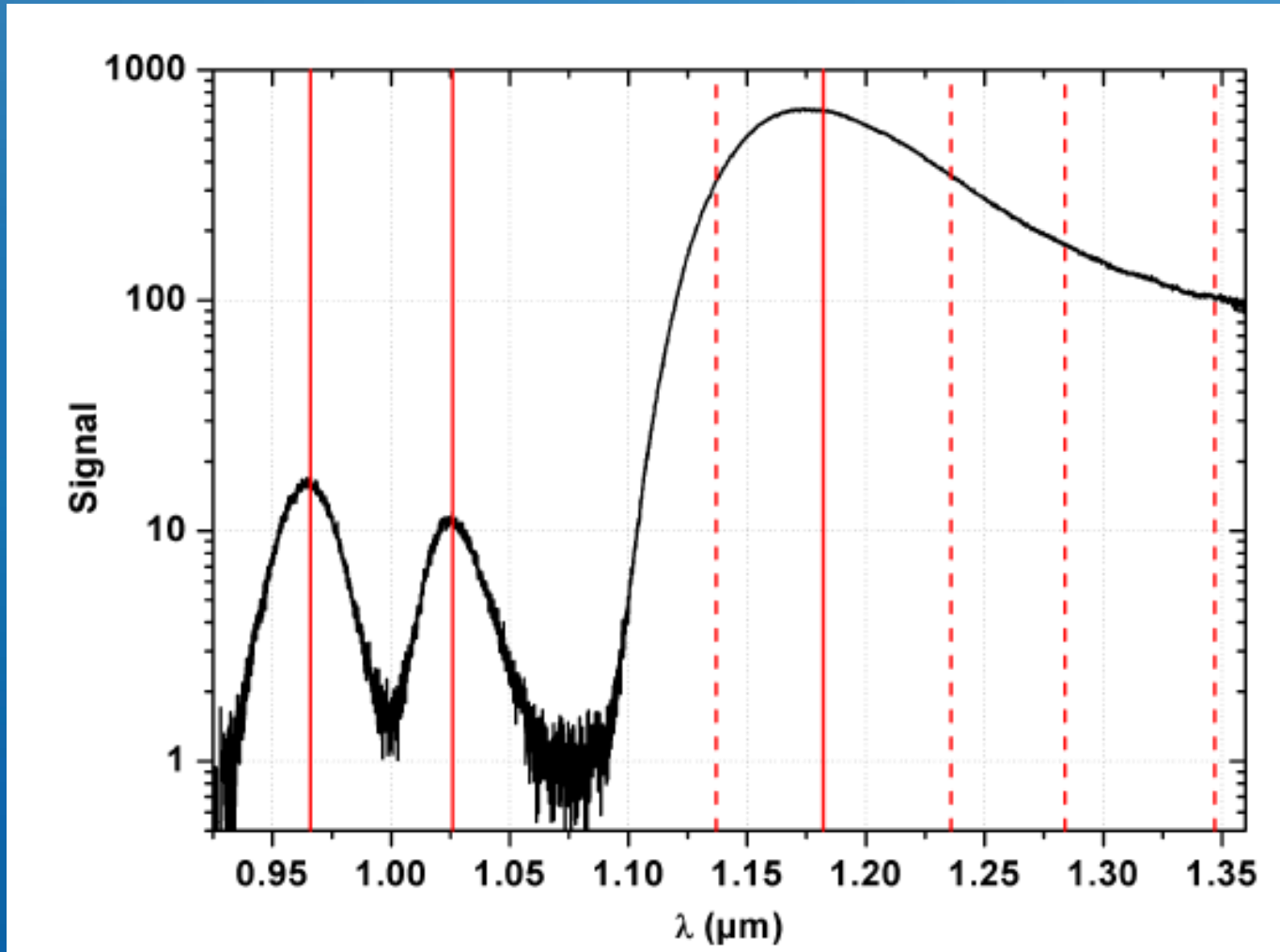
High quality IR spectrum of the Ar-Xe mixture (IR PMT, seed money!)

## The efficiency issue!

Photons per MeV deposited for both the VUV and IR emission

- Emission from the gas can be used as a calibrated light source in the VUV!
- Sensitivity data of an InAs detector can be used in the IR

Result for 10 keV electron excitation:

Pure argon:  $(22000 \pm 3000) / \text{MeV}$

Xenon in Ar-Xe:  $(20000 \pm 6000) / \text{MeV}$

IR emission:  $(13000 \pm 4000) / \text{MeV}$

Literature value for pure argon 40000 /MeV for 976 keV electrons

T. Doke et al. "Estimation of absolute photon yields in liquid argon and xenon for relativistic (1MeV) electrons". Nucl. Instrum. Meth. A 291, 617,1990.



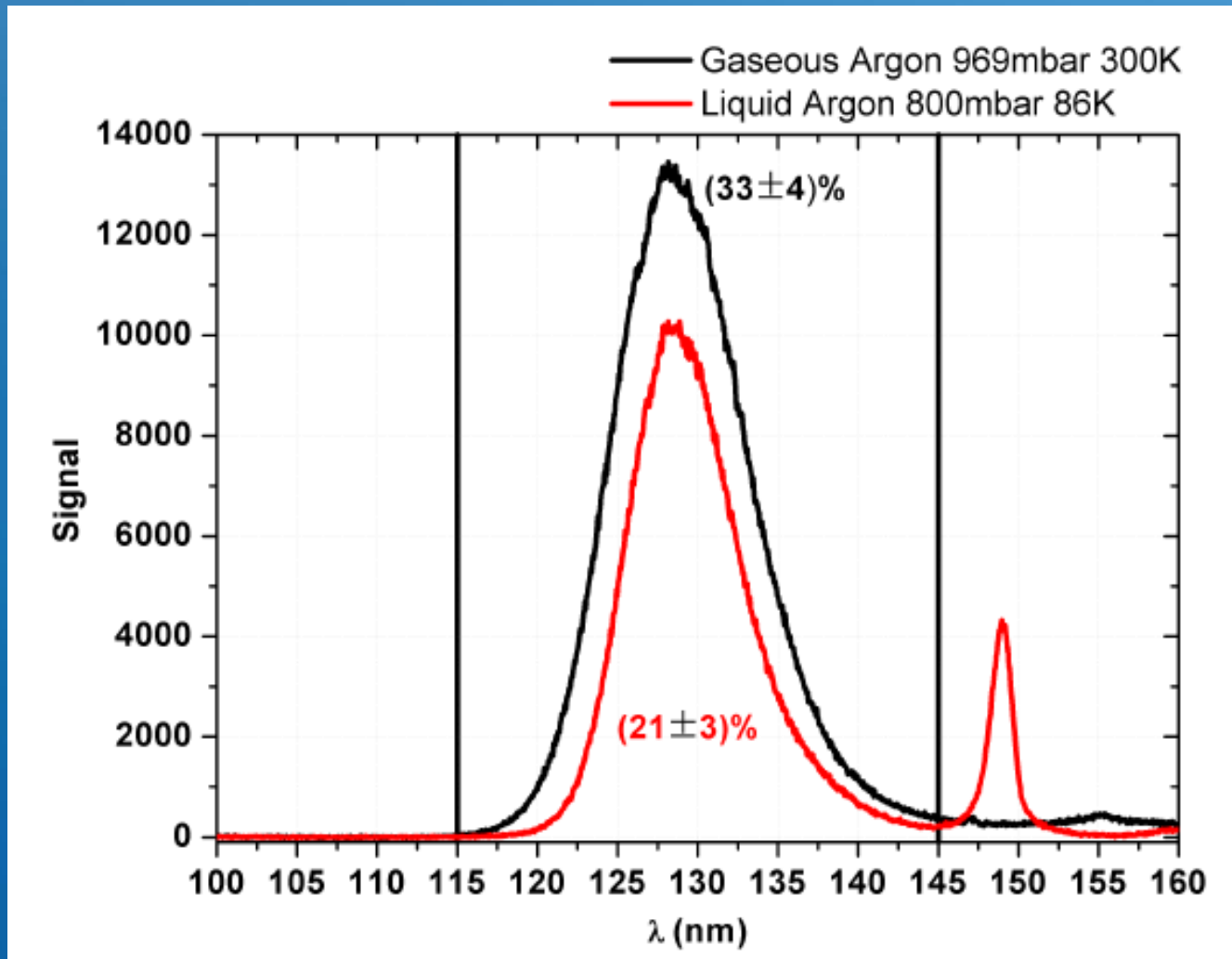

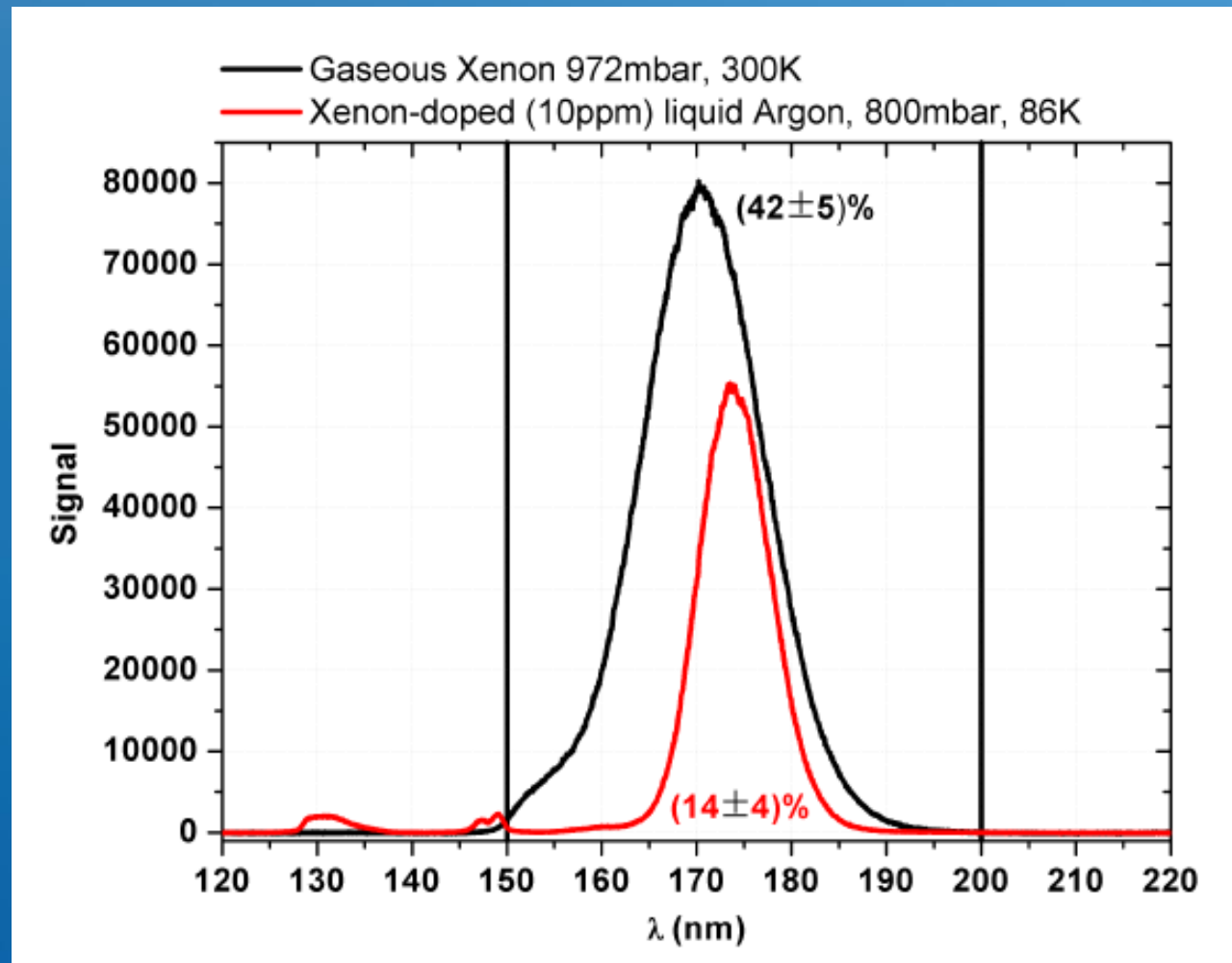

## Time structure of the light emission in the VUV and IR

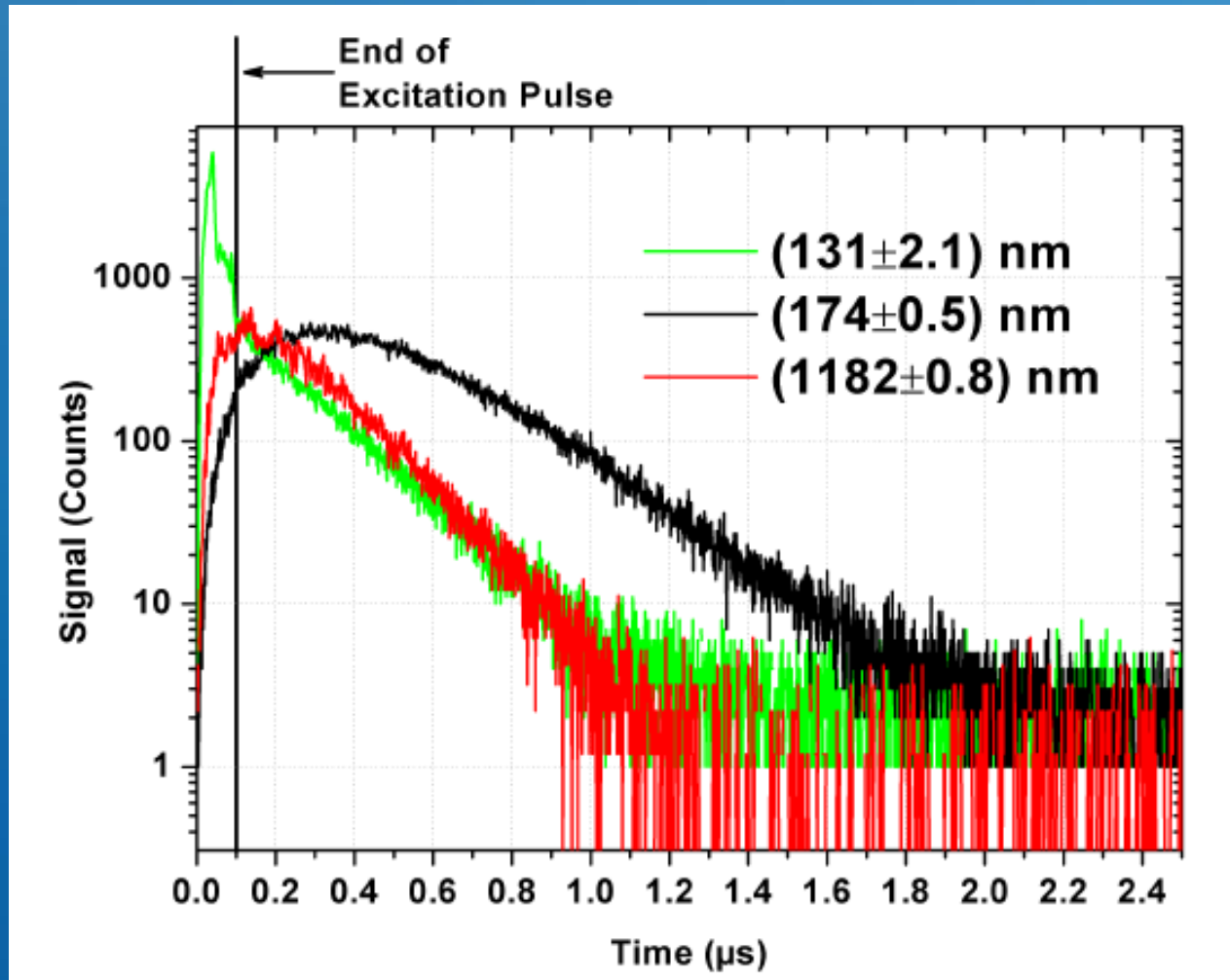

Absorption spectrum of an Ar-Xe mixture:  
a hint towards an assignment of the IR emission!

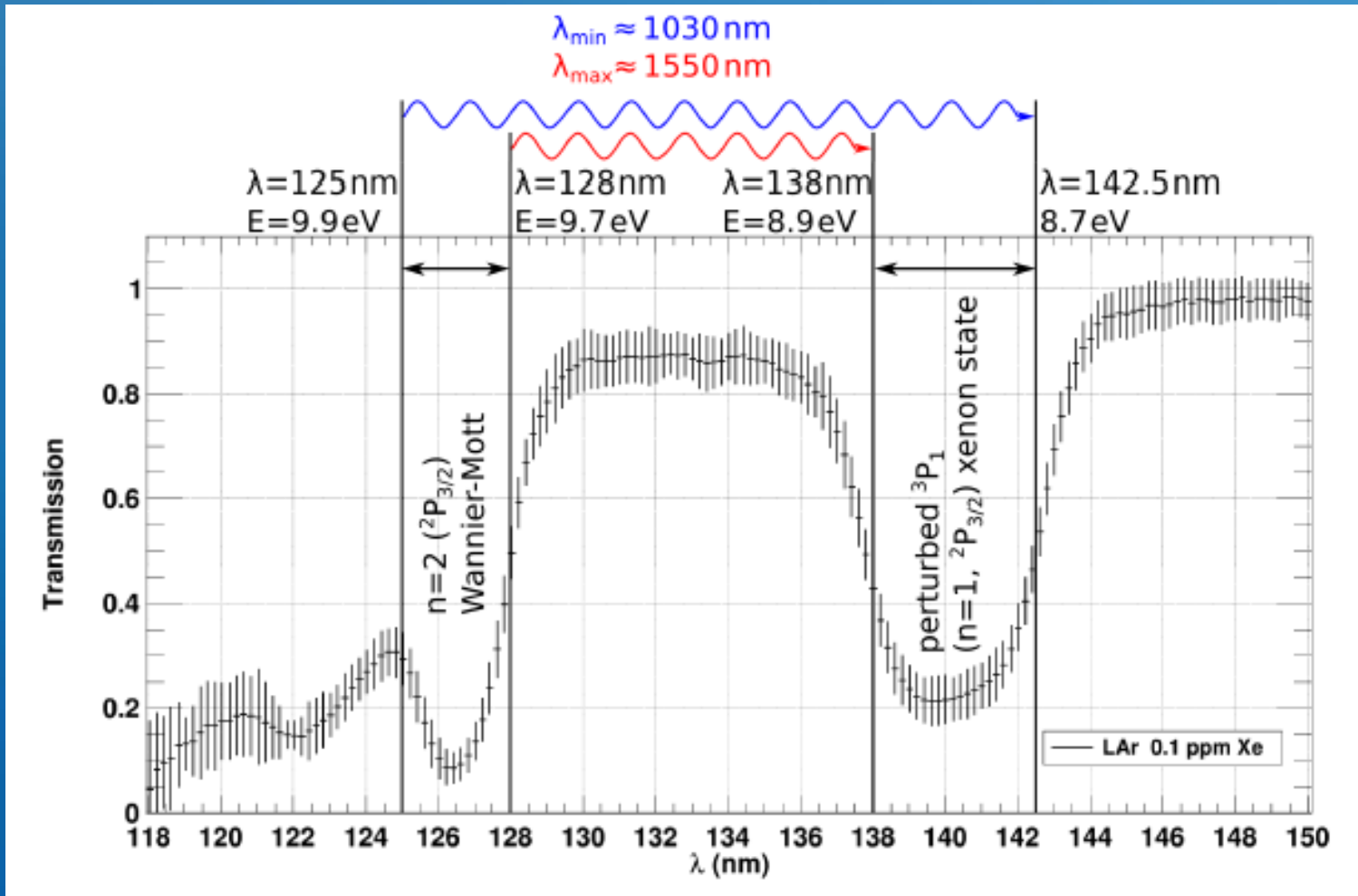

# Energy transfer scheme:

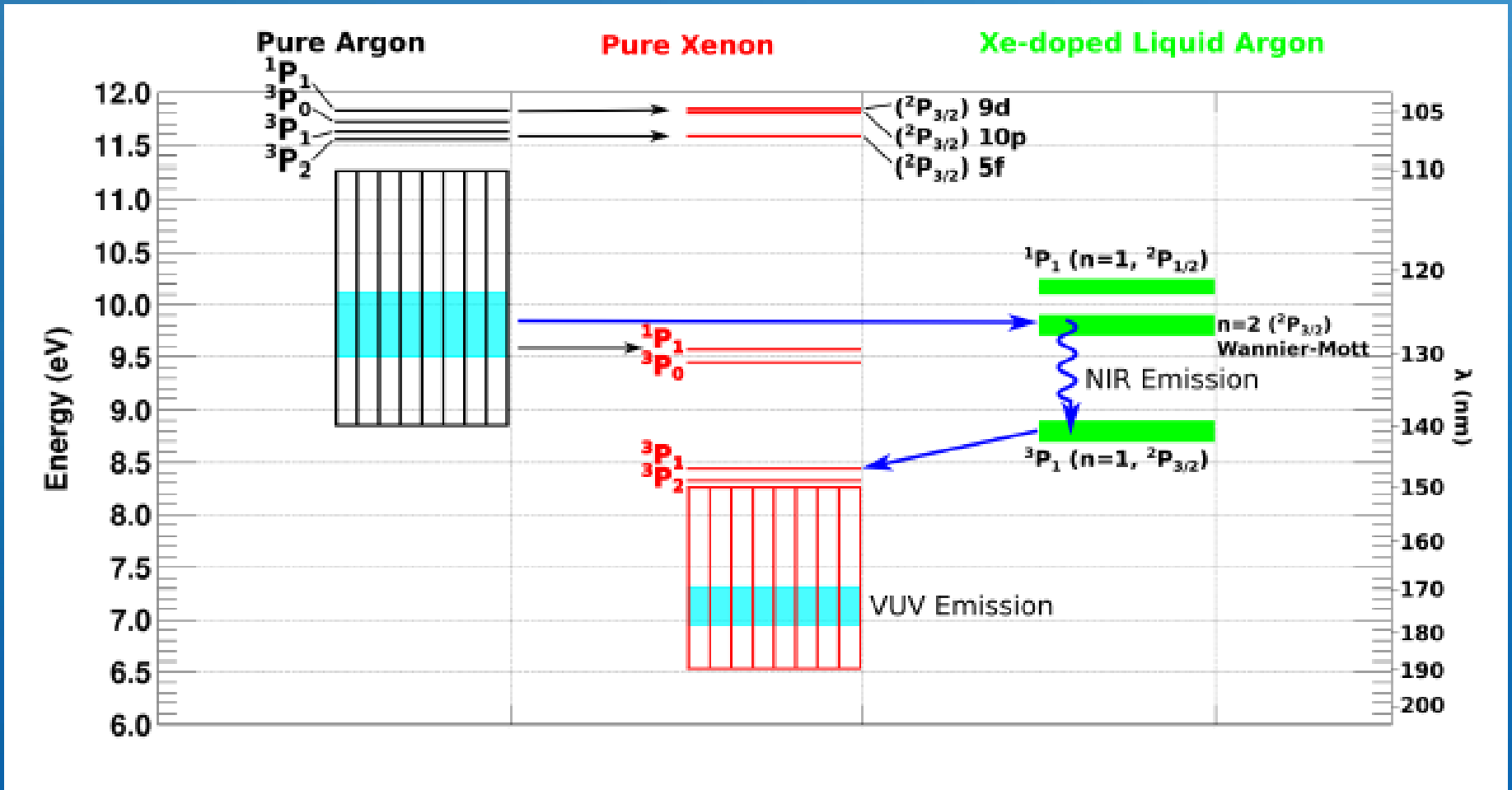

# Absorption issues



# „Fogging“ of a $MgF_2$ window (adsorption of water vapor)

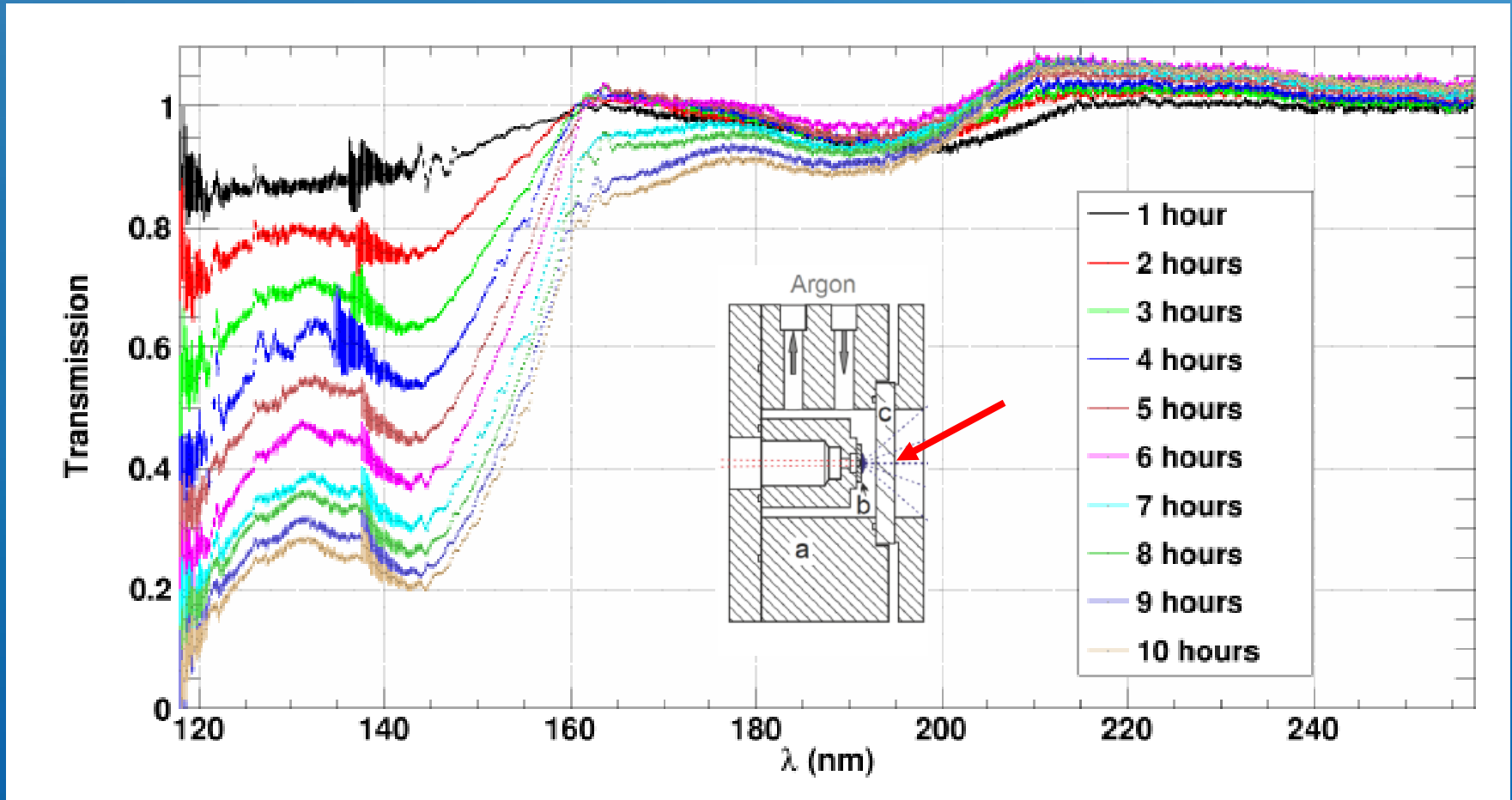

## The real issue for detector physics: absorption of pure liquid argon

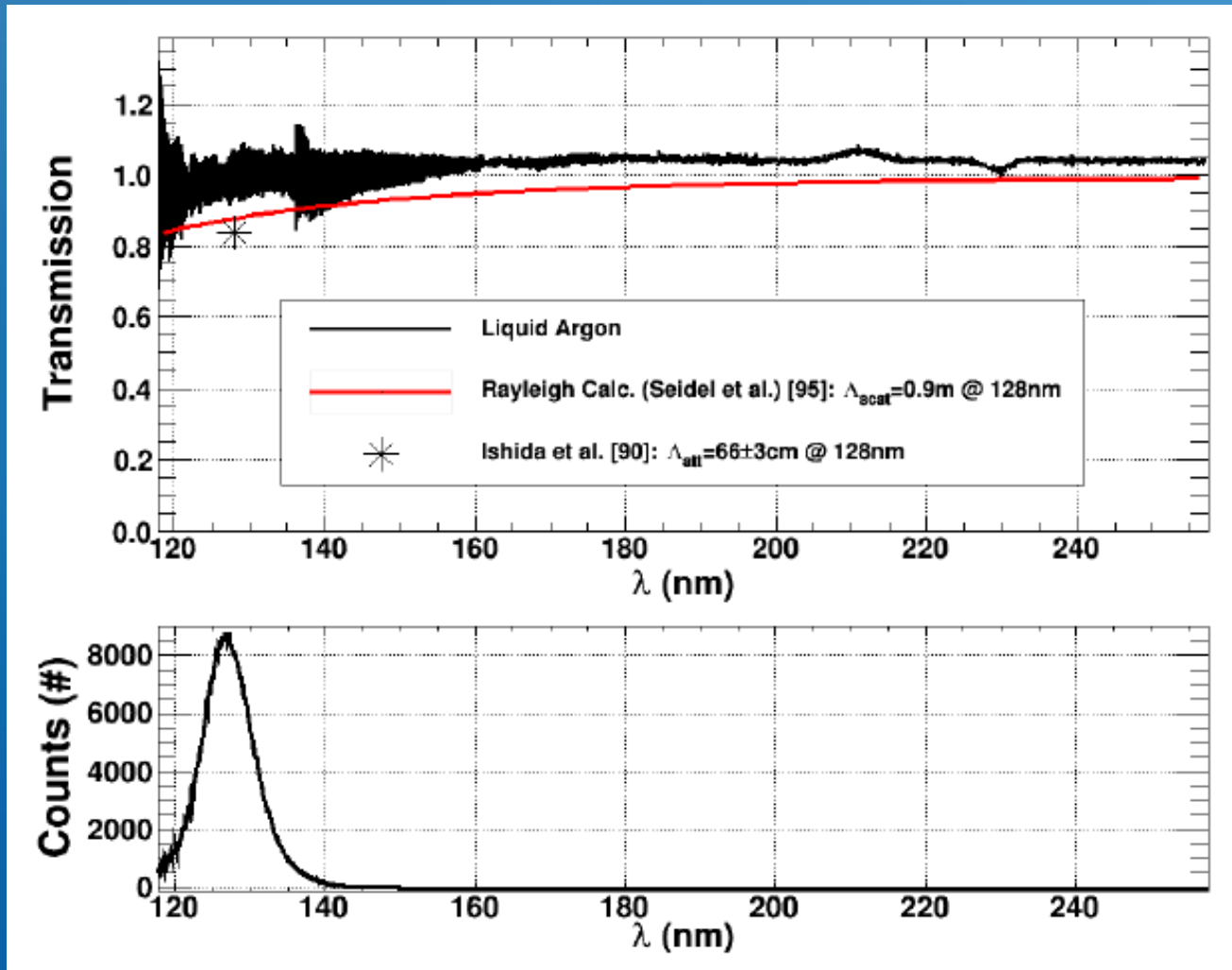

## VUV absorption spectra of Ar-Xe mixtures

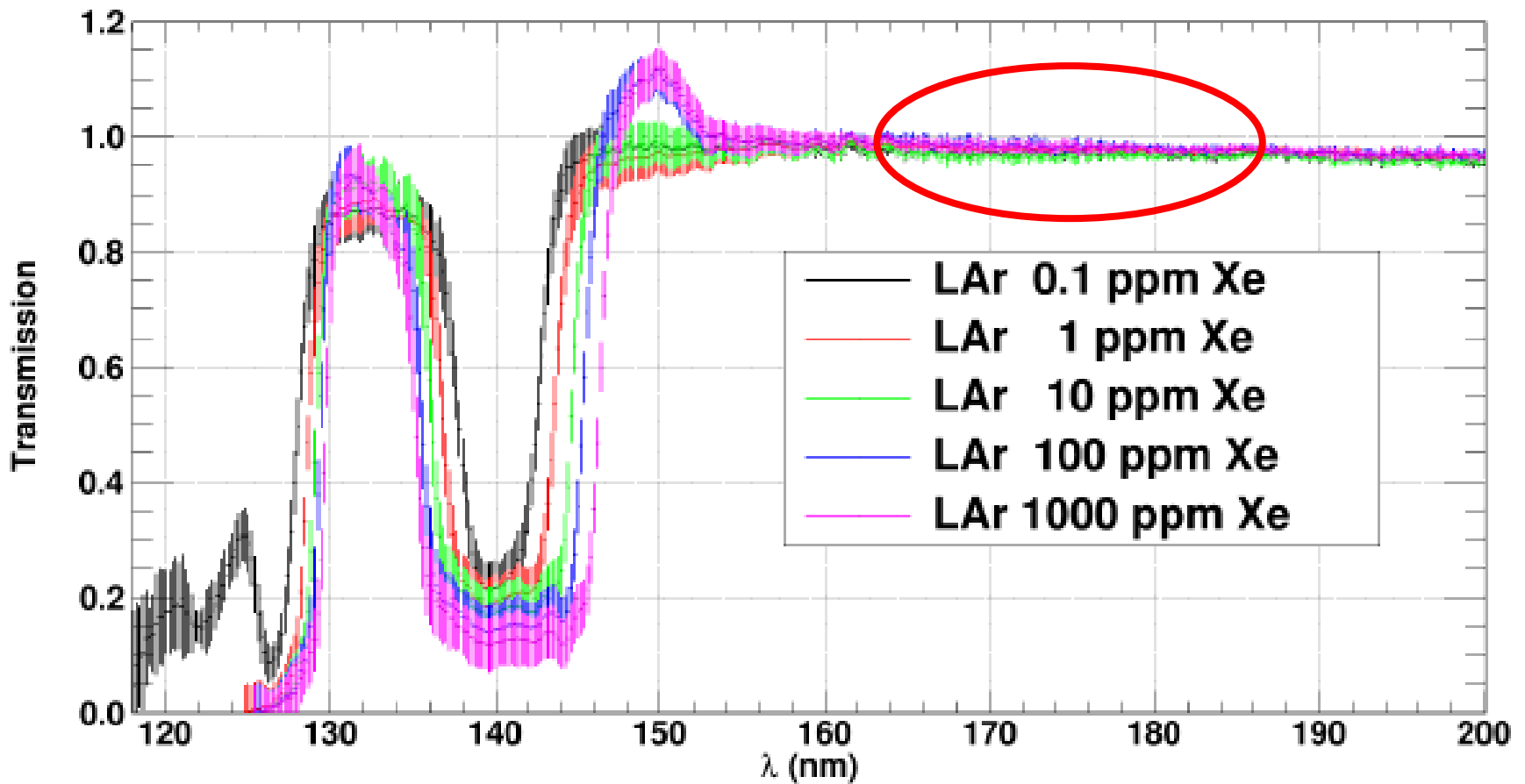

## Summary of the spectroscopic results:

We have collected a lot of spectroscopic information about pure liquid argon

We have discovered a strong infrared emission from liquid 10ppm xenon in argon mixtures

## Question:

Can a detector with light detection alone (VUV and IR) be useful for particle identification and thereby for background suppression?



Heavy ions excite the gas both directly and via secondary electrons!

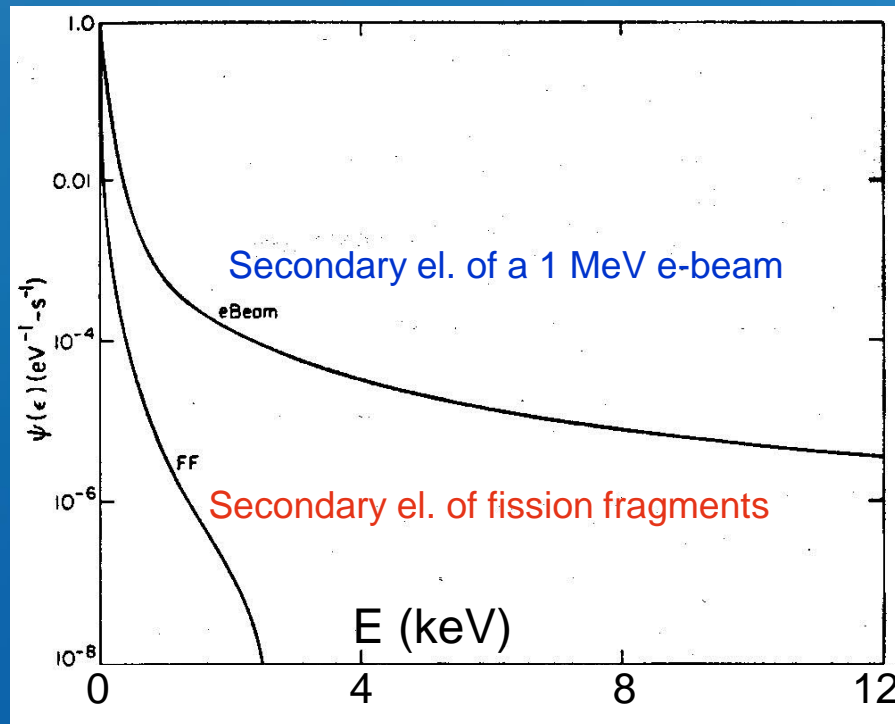
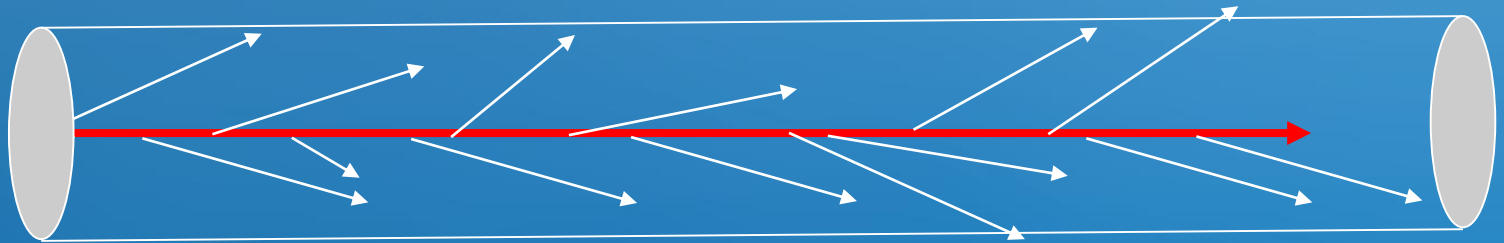

T.J. Moratz and  
M. Kushner  
J.Appl. Phys.  
63, 1798 (1988)



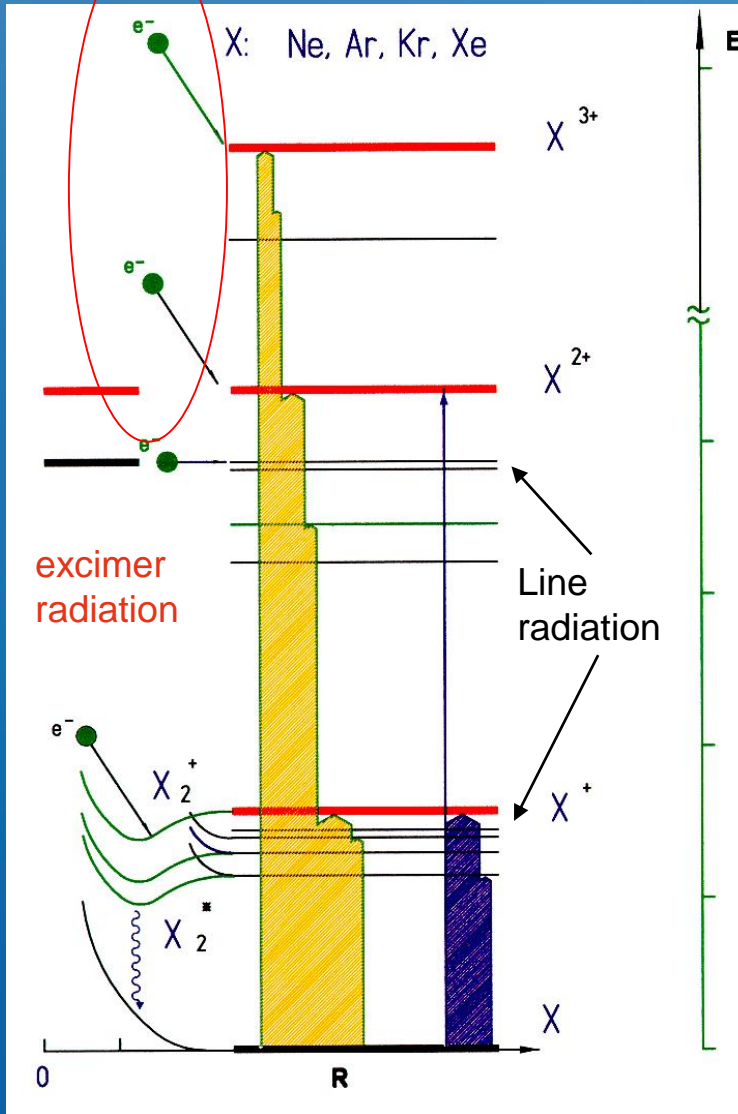

Excitation by heavy ion projectiles

Excitation by the secondary electrons

Result:

Excited atoms and ions in a cold environment !!!

Present experiments: Excitation of a liquid Ar-Xe mixture with various ions from the Munich Tandem Accelerator (PhD thesis A. Himpsl)

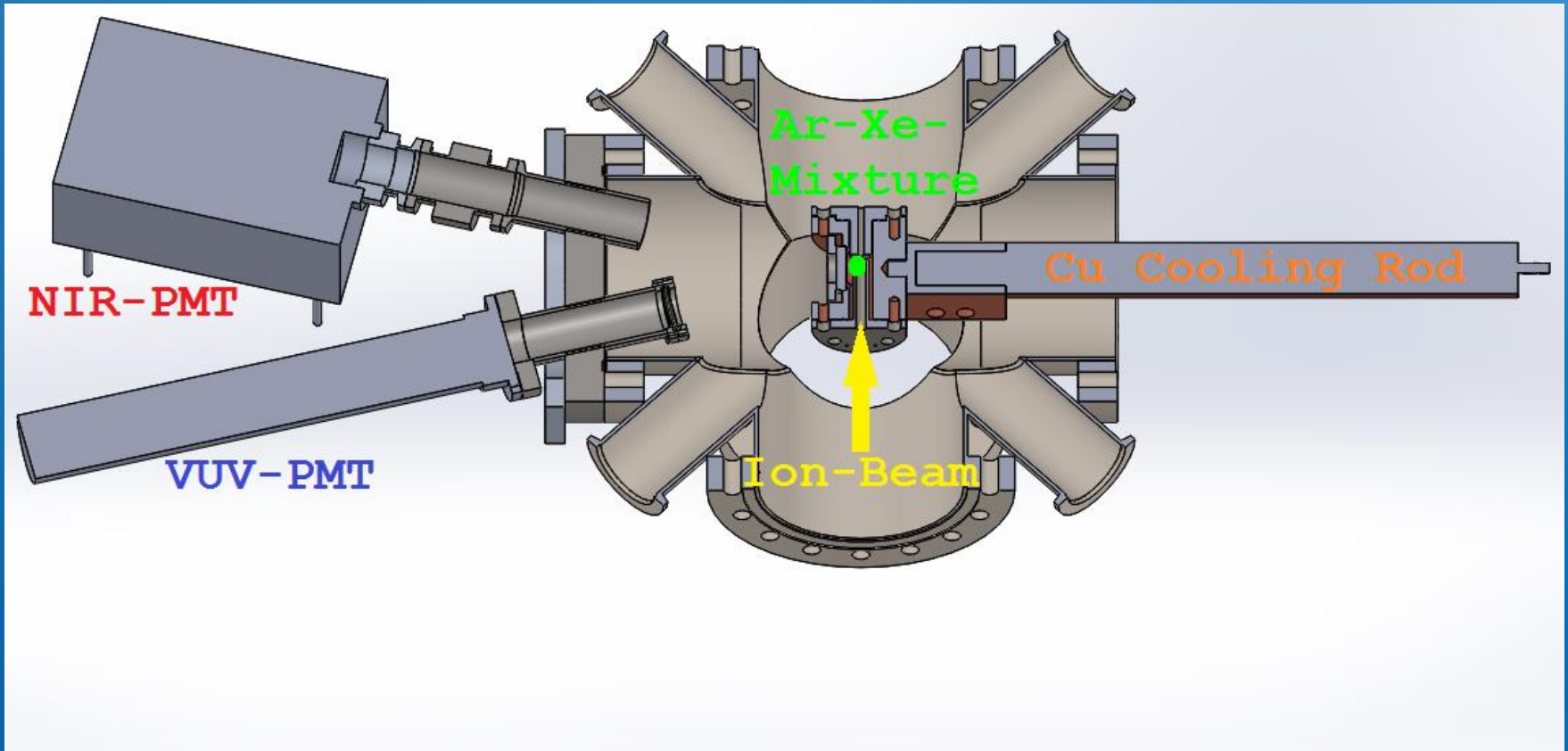

# The vision: a liquid Ar-Xe detector with VUV and IR particle identification

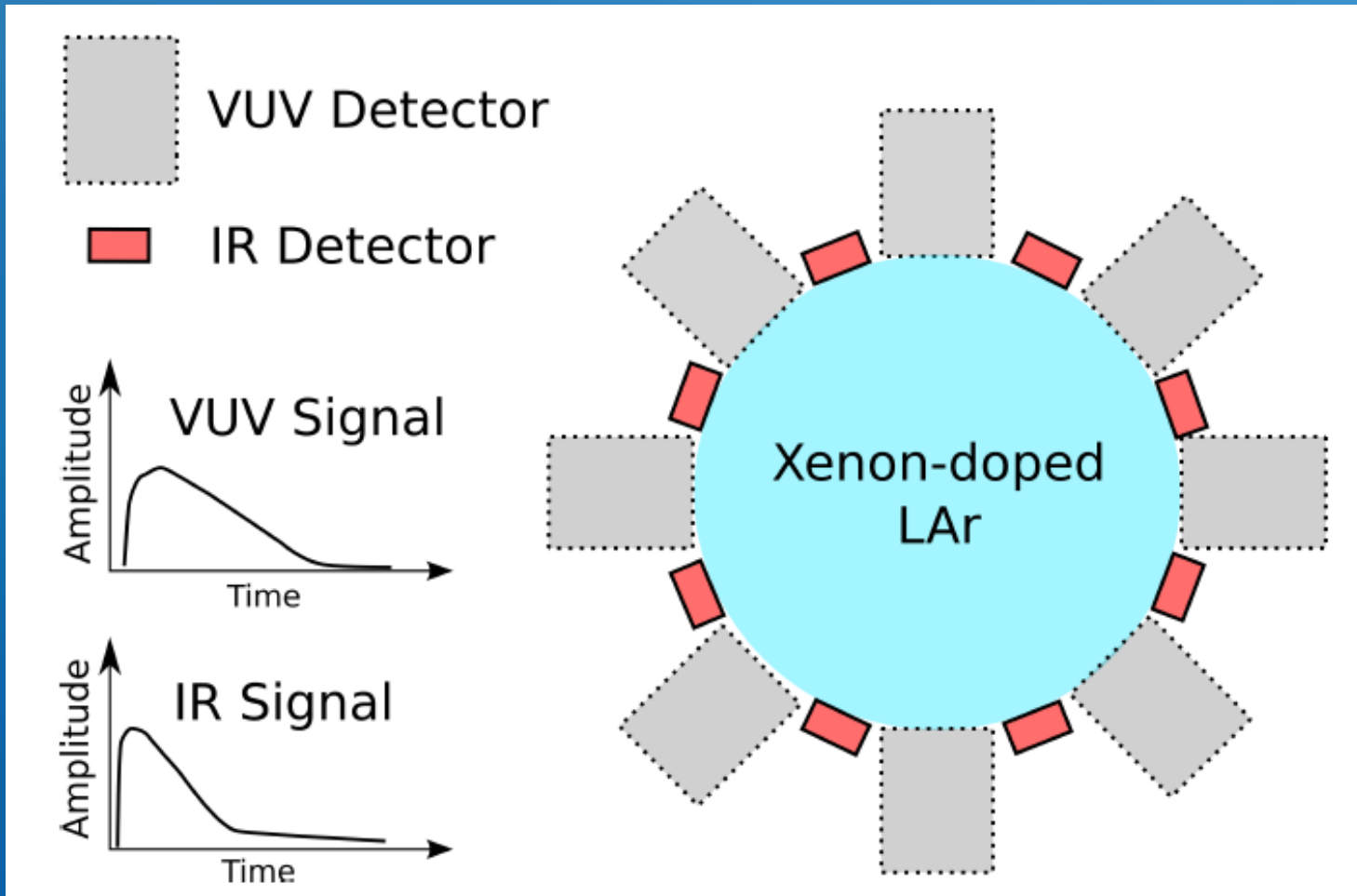

## Publications in this context

T. Heindl et al. EPL, 91 (2010) 62002

T. Heindl et al., 2011 JINST 6 P02011

M. Hofmann et al., Eur. Phys. J. C (2013) 73:2618

A. Neumeier et al., Europhys. Lett. 109 12001, 2015 (editor's choice)

A. Neumeier et al., Europhys. Lett. 106 32001, 2014 (editor's choice)

A. Neumeier et al., NIM A800 (2015) 70–81

A. Neumeier et al., Eur. Phys. J. C 72:2190, 2012



We thank the Universe Cluster for their support in the form of a  
Seed Money Project !



Thank you for your attention !

