

A.Kisiel,

*Warsaw University of Technology  
Joint Institute of Nuclear Research*

NICA

Volga  
river





# Joint Institute for Nuclear Research (JINR) – International Intergovernmental Organization established through the Convention of March 26, 1956 by 11 founding States and registered with the United Nations on 1 February 1957

## 18 Member States



## 6 associated countries



*Governed by the Committee of Plenipotentiary representing governments of 18 countries*



# NICA (Nuclotron based Ion Collider fAcility)

## Main targets:

- *study of hot and dense baryonic matter*  
at the energy range of *max baryonic density*
- *investigation of nucleon spin structure, polarization phenomena*



- *development of accelerator facility for HEP @ JINR*
- *construction of Collider of relativistic ions from **p** to **Au**,  
polarized protons and deuterons*

*with max energy up to  $v_{s_{NN}} = 11 \text{ GeV (Au}^{79+})$  and  $= 27 \text{ GeV (p)}$*

# NICA -dedicated QCD machine

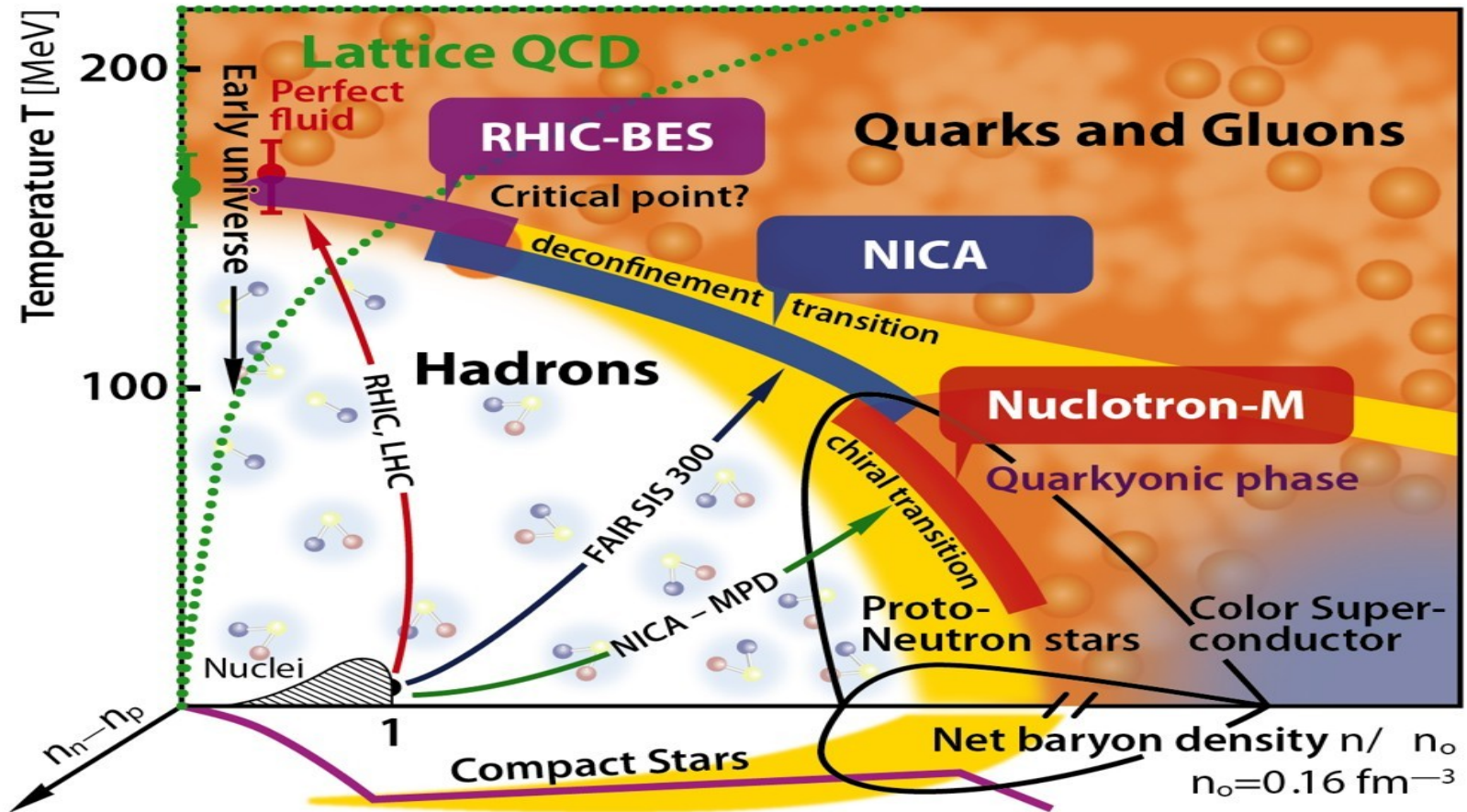

# Present and future HI experiments

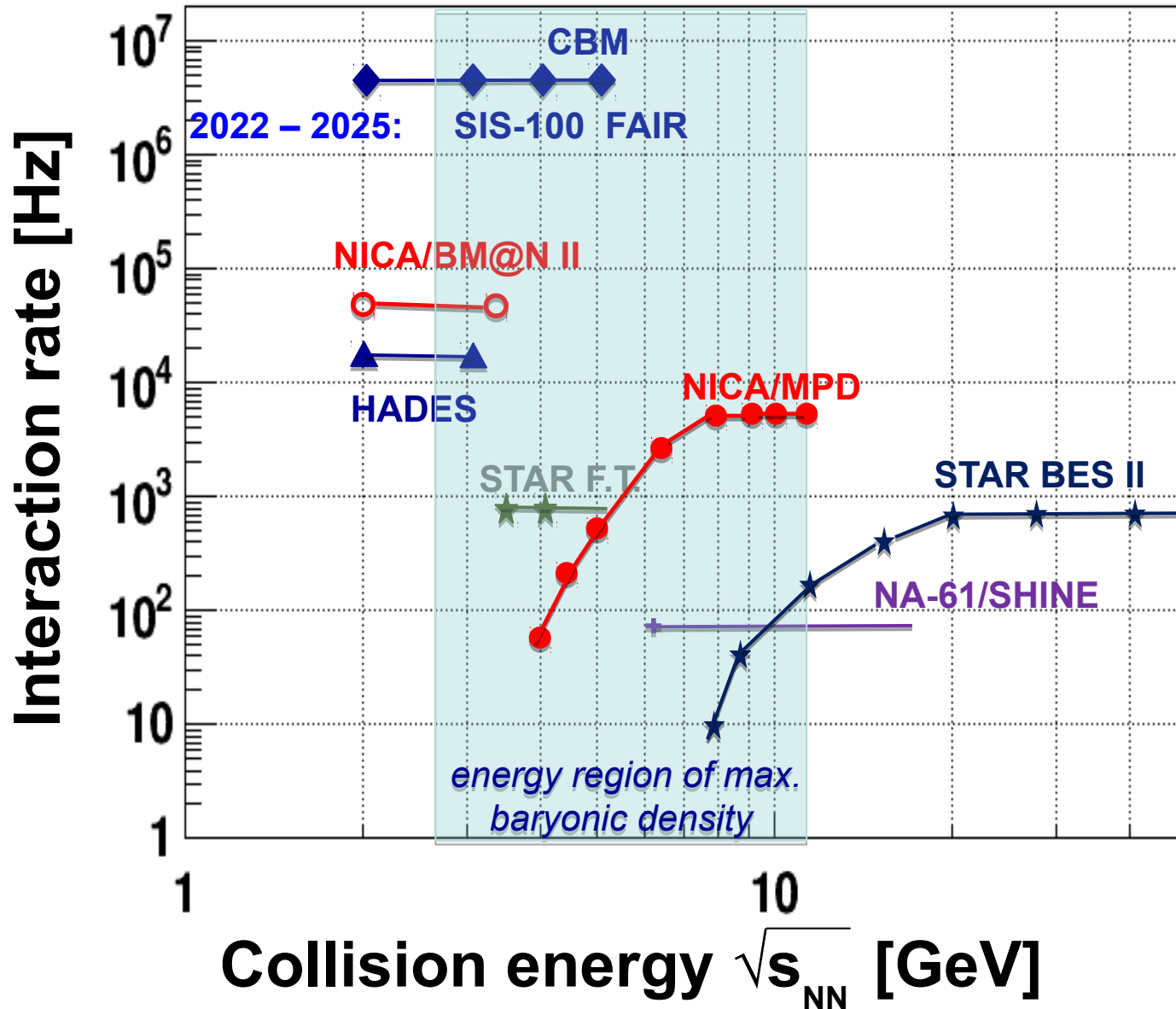

# New issues: NICA White Paper, SQM proceedings



*Physics targets for the exploration of first order phase transitions in the region of the QCD phase diagram accessible to NICA & FAIR and possible observable effects of a “mixed phase” indicated in the release of the “NICA White Paper” as a Topical Issue of the **EPJ A** (July 2016).*

ISSN 1742-6598

**JOURNAL OF PHYSICS: CONFERENCE SERIES**  
The open access journal for conferences  
15th International Conference on  
Strangeness in Quark Matter  
(SQM2015)

Dubna, Russia  
6–11 July 2015

**Editors:** David E. Alvarez-Castillo, David Blaschke, Vladimir Kekelidze,  
Victor Matveev and Alexander Sorin

Volume 668 2016

[jpcs.iop.org](http://jpcs.iop.org)



**NICA**  
**SQM**  
DUBNA 2015

**IOP Publishing**

The European Physical Journal volume 52 · number 8 · august · 2016

**EPJ A**  
Recognized by European Physical Society

Hadrons and Nuclei

**Topical Issue on Exploring Strongly Interacting Matter at High Densities - NICA White Paper**  
edited by David Blaschke, Jörg Aichelin, Elena Bratkovskaya, Volker Friese, Marek Gazdzicki, Jürgen Randrup, Oleg Rogachevsky, Oleg Teryaev, Viacheslav Toneev

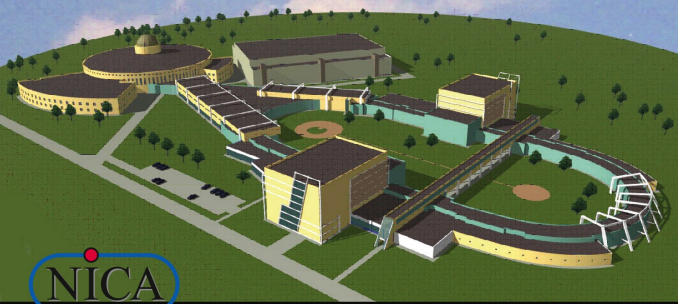

**NICA**

From: Three stages of the NICA accelerator complex  
by V. D. Kekelidze et al.

 **Springer**

**111** contributions,  
**188** authors  
from **24** countries

# NICA basic facility



BM@N

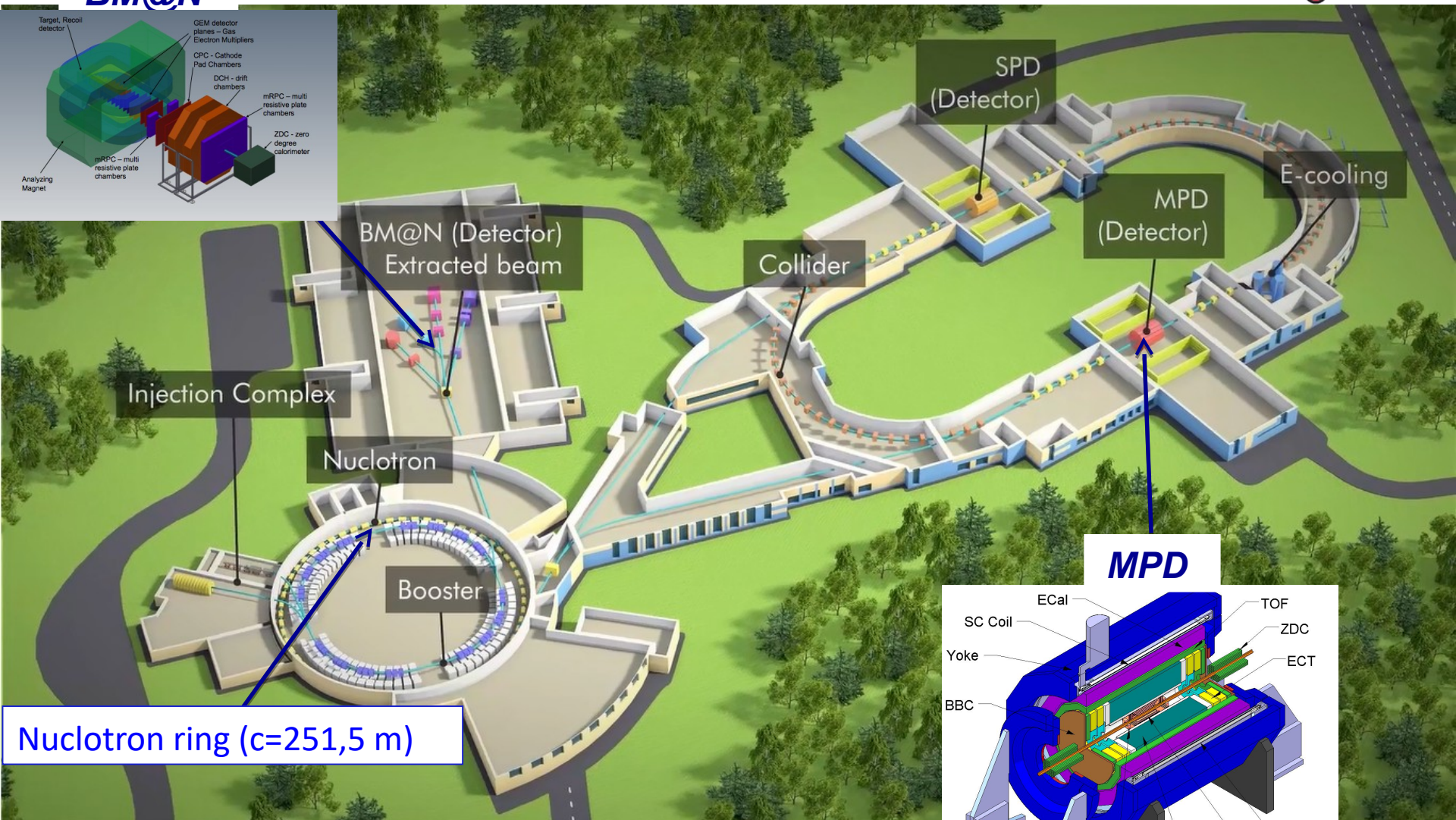
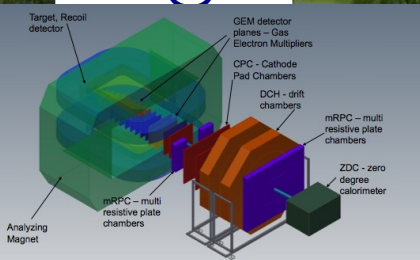

MPD

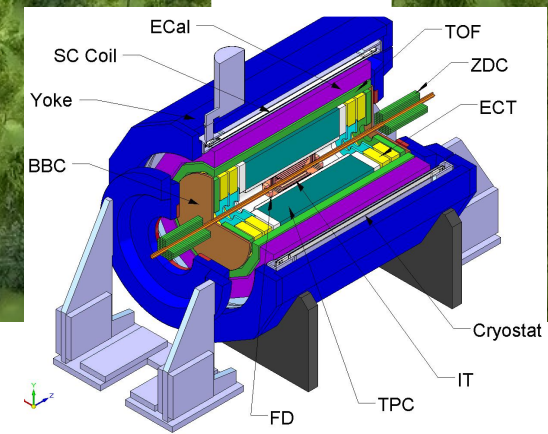

# Structure of Accelerator Complex and Operation Regimes

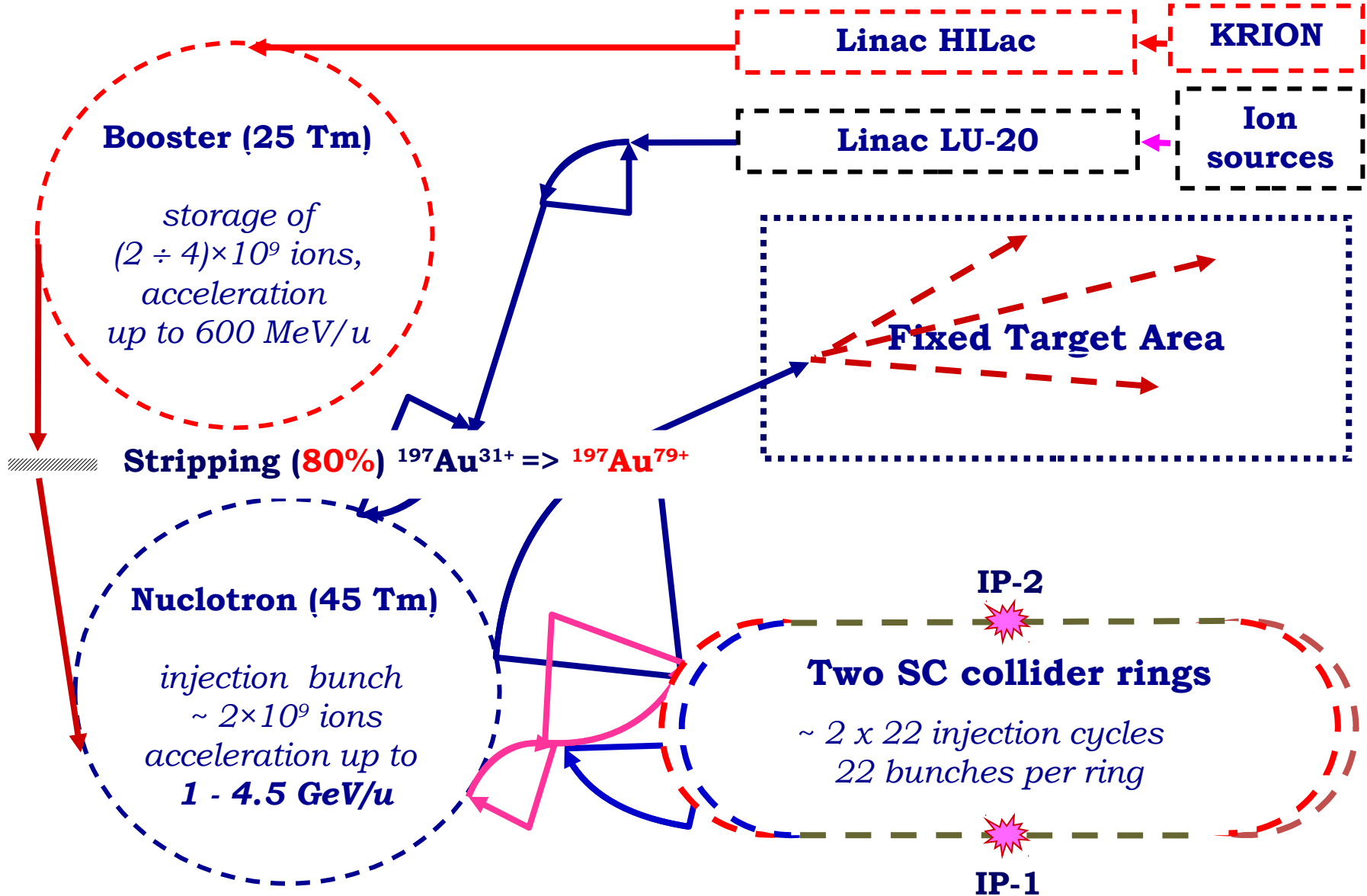

# NICA-PL Consortium

---

- Agreement of the four Polish institutions (Warsaw University of Technology, University of Warsaw, National Center of Nuclear Research in Świerk, Jan Kochanowski University of Kielce) “to carry out scientific research, specialist education, design and construction of the scientific and control equipment for the purpose of the NICA research complex at the Joint Institute of Nuclear Research in Dubna”.
- Consortium is open for new members and foresees the addition of more Polish institutions (currently negotiating with University of Wrocław, other institutions also expressed interest)
- Members of the Consortium show explicit desire to join MPD and/or BM@N Collaborations
- Consortium can be a common vehicle for application for funding in selected funding agencies (national and European)

# The NICA-PL Consortium



## Warsaw U. of Technology

Long term involvement in heavy-ion collision exp. in CERN (ALICE, NA49, NA61, CMS), RHIC (STAR), interest in heavy-ion physics, detector construction, student participation, electronics, mechanical engineering, control systems



## University of Warsaw

Long term involvement and large experience in heavy-ion collision exp. in CERN (CMS, NA49, NA61), DESY, etc., interest in heavy-ion physics, detector construction, student participation

## National Center for Nuclear Research

Large experience in heavy-ion collision exp. in CERN (ALICE, NA49, NA61, CMS), RHIC (STAR), interest in heavy-ion physics, detector construction, electronics, mechanical engineering, control systems



## Jan Kochanowski University in Kielce

Long term involvement in heavy-ion collision exp. in CERN (WA98, NA49, NA61), interest in heavy-ion physics, detector construction, astrophysical measurements, student participation



# MultiPurpose Detector (MPD) Collaboration:

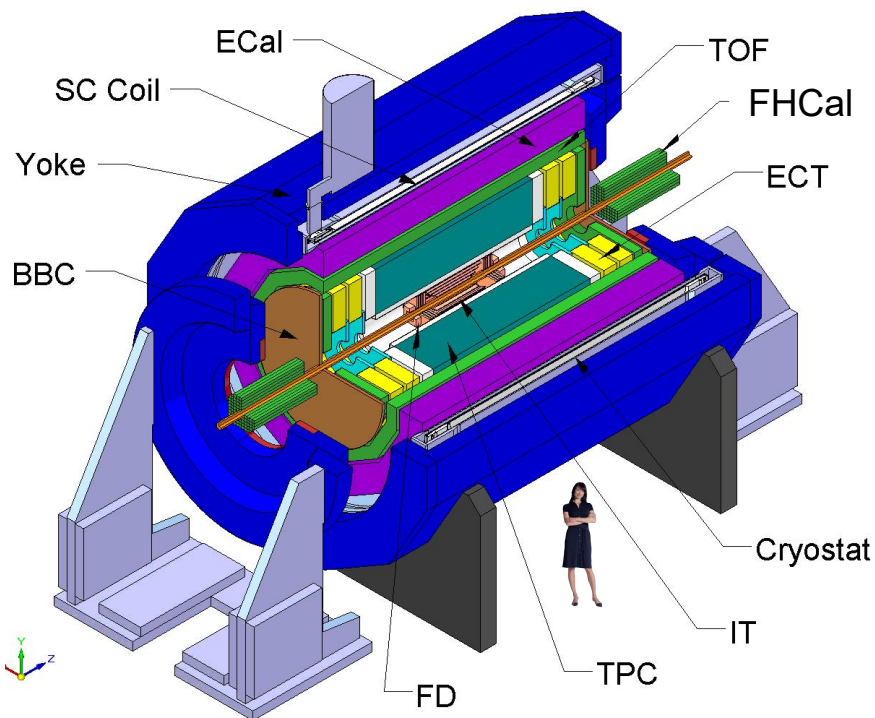

- IHEP, Beijing, **China**;*
- University of South China, **China**;*
- Palacky University, Olomouc, **Czech Republic**;*
- NPI CAS, Rez, **Czech Republic**;*
- Tbilisi State University, Tbilisi, **Georgia**;*
- Tubingen University, Tubingen, **Germany**;*
- Tel Aviv University, Tel Aviv, **Israel**;*
- Joint Institute for Nuclear Research**;*
- IPT, Almaty, **Kazakhstan**;*
- UNAM, Mexico City, **Mexico**;*
- Institute of Applied Physics, Chisinev, **Moldova**;*
- WUT, Warsaw, **Poland**;*
- NCNR, Otwock – Świerk, **Poland**;*
- UWr, Wrocław, **Poland**;*
- Jan Kochanowski University, Kielce, **Poland**;*
- INR RAS, Moscow, **Russia**;*
- MEPhI, Moscow, **Russia**;*
- PNPI, Gatchina, **Russia**;*
- INP MSU, Moscow, **Russia**;*
- SPSU - Dept. of NP, **Russia**;*
- St. Petersburg, **Russia**;*
- SPSU – Dept. of HEP, St. Petersburg, **Russia**;*
- KI NRS, Moscow, **Russia**;*

- Baku State University, NNRC, **Azerbaijan**;*
- University of Plovdiv, **Bulgaria**;*
- University Tecnica Federico Santa Maria, Valparaiso, **Chile**;*
- Tsinghua University, Beijing, **China**;*
- USTC, Hefei, **China**;*
- Huizhou University, Huizhou, **China**;*
- Institute of Nuclear and Applied Physics, CAS, Shanghai, **China**;*
- Central China Normal University, **China**;*
- Shandong University, Shandong, **China**;*

# Multi-Purpose Detector (MPD)

Stage 1 (2020): TPC, TOF, ECAL, ZDC, FFD

Stage 2 (~2023): + ITS + EndCap (CPC, Straw, TOF, ECAL)

- tracking:  
 $up\ to\ |\eta| < 1.8$  (TPC)  
 $1.2 < |\eta| < 2.5$  (CPC, Straw)
- PID:  
 $had., e, \gamma$  (TOF, TPC, ECAL)
- Reaction:  
 $centrality\ \&\ plane$   
 $determination$  (FHCAL)

Plan:  
 $overall\ commissioning$   
 $starts\ in\ 2020$

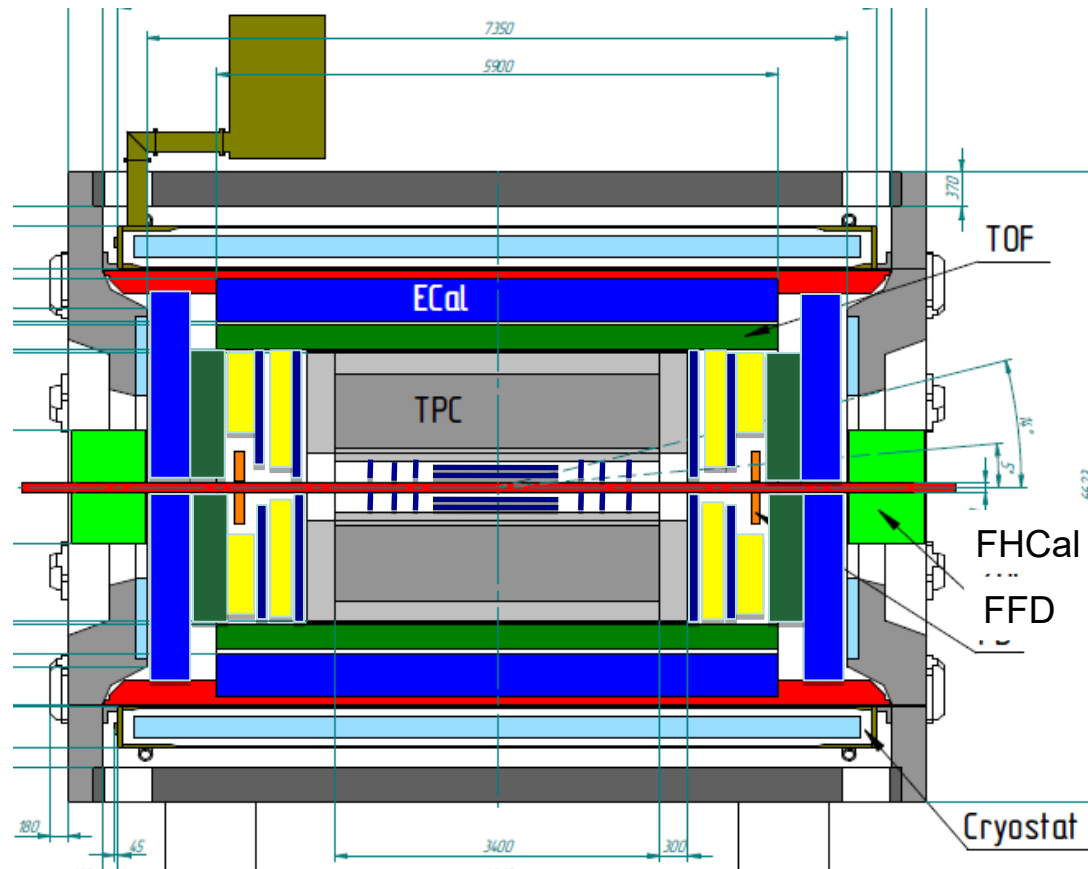

# Second MPD Collaboration Meeting

## 29-30 October 2018

<http://jinrmag.jinr.ru/pdf2/18num45-46.pdf>

<http://mpd.jinr.ru/experiment/>



*New member institutes (now 32 institutes from 10 countries)*

*Spokesperson election: Adam Kisiel (WUT, Poland)*

*IB Board Chair election: Fuqiang Wang (ZJHU, China)*

*Project manager endorsement: Slava Golovatyuk (JINR)*

# Example project: NICA Multi Purpose Detector – Engineering Support Platform – Electronics Housing

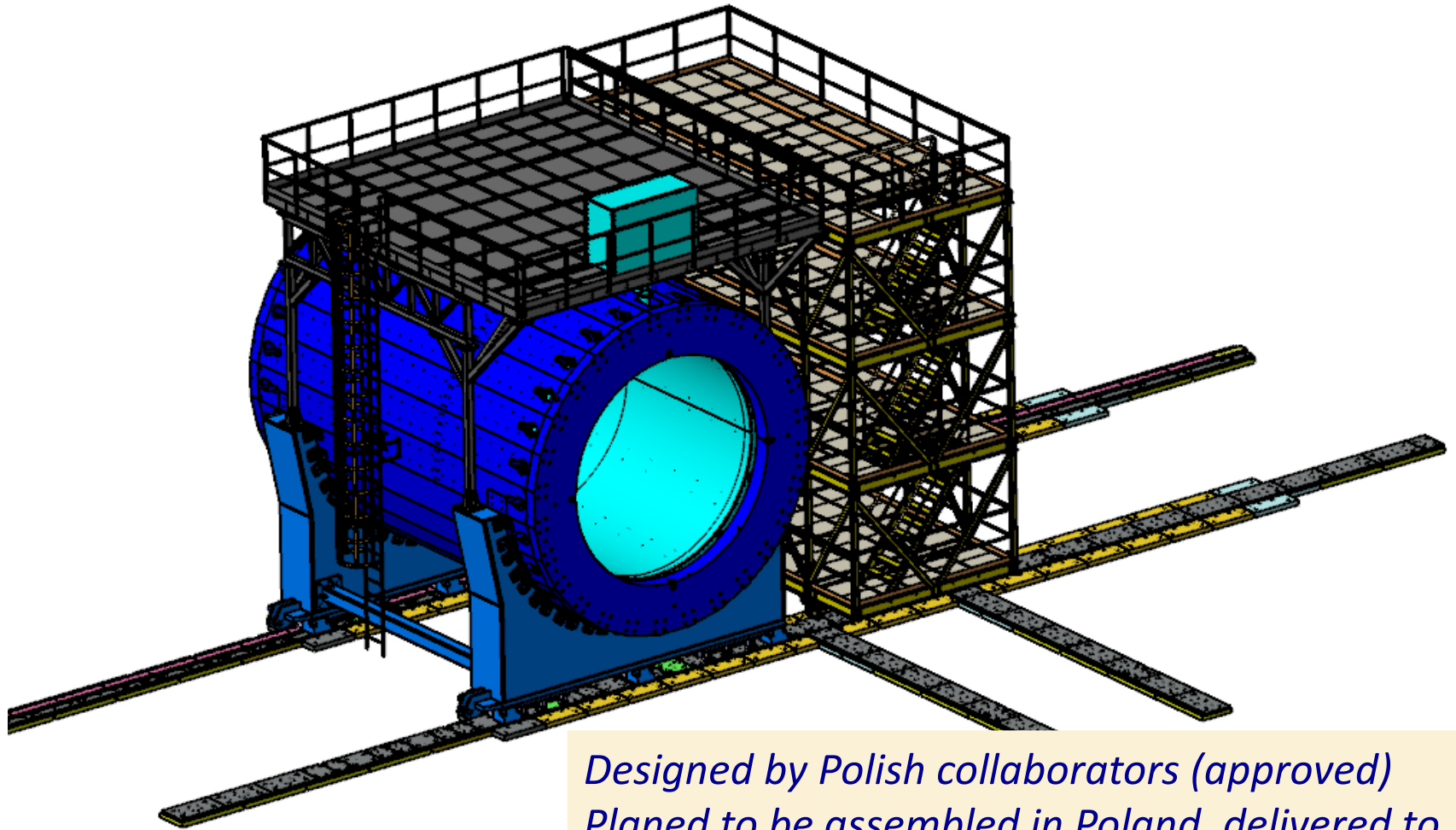

*Designed by Polish collaborators (approved)  
Planned to be assembled in Poland, delivered to JINR  
Strong participation of Polish industrial partners*

# Slow Control System Platform

## Time-of-Flight Gas System

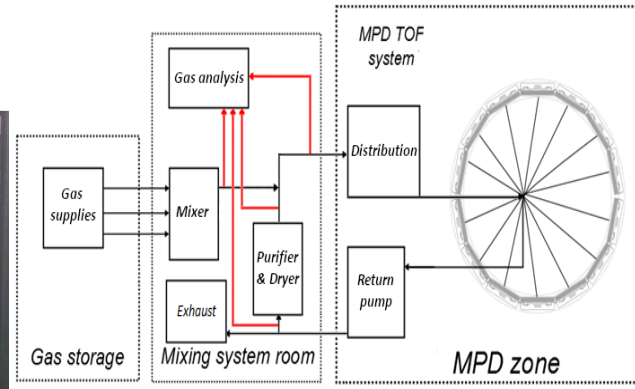

*Designed by Polish collaborators (approved)  
Final stages of assembly in JINR TOF test site  
Strong participation of Polish industrial partners*

# MPD Cosmic Ray Detector (MCORD) - proposition

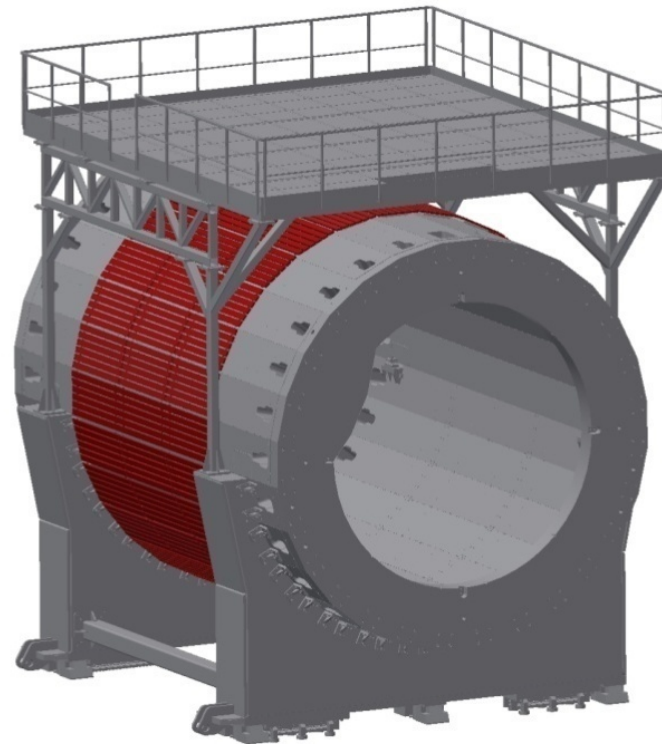
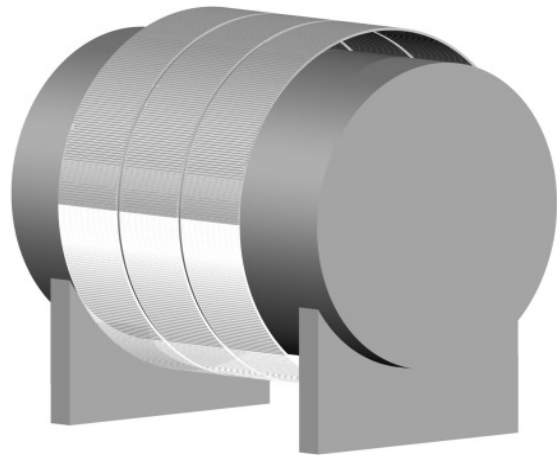
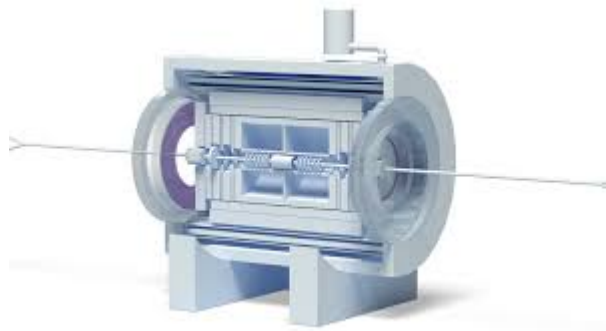

Single surface on full circumference

Scintillator slabs read out by SiMP modules (both ends)

*Designed by NICA-PL members (First DAC round)*

*Possibility to fully construct in Poland*

*Strong participation of Polish industrial partners*



# MCORD - MicroTCA configuration



Standard MTCA crate  
5 or 12 AMC modules  
Crate number depends on channel  
count and sampling speed

At 250MS/s: 192 channels / crate  
At 125MS/s: 384 channels / crate  
At 80MS/s: 576 channels / crate  
At 50MS/s: 768 channels / crate

Analog Front-End module

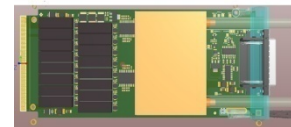

FPGA mezzanine card (FMC)



AMC FMC carrier board



MTCA Carrier Hub

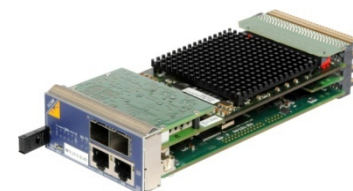

**For several MTCAs one main MCH  
concentrates data from slave MHCs to  
generate final muon trigger**

# “Team for the future of NICA”



- Student internship program co-financed by JINR and WUT attracting young dedicated staff to the NICA project (more than 30 participants in 2017 and 2018, more planned)

# BARYONIC MATTER DENSITY FRONTIER

NICA is included in the ESFRI ROADMAP-2016 and in the NuPECC Long Range Plan 2017 - Perspectives in Nuclear Physics

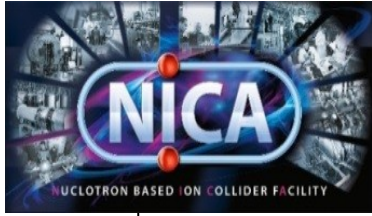

## Main Research Infrastructures in Particle and Nuclear Physics

### PARTICLE PHYSICS

### NUCLEAR PHYSICS

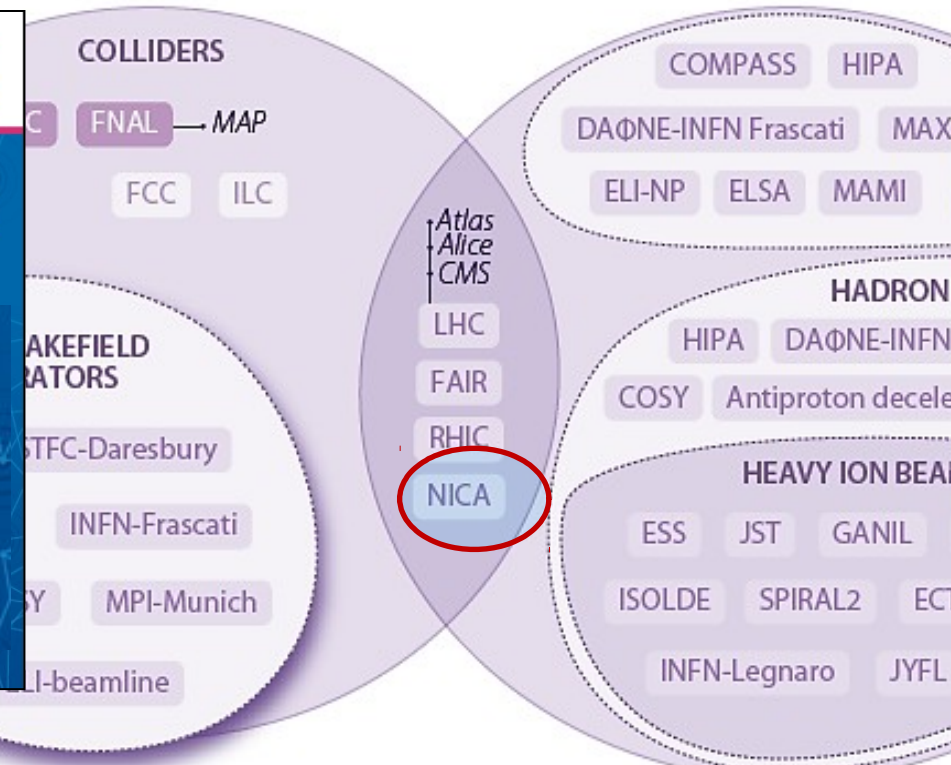

**NuPECC** Long Range Plan 2017 Perspectives in Nuclear Physics

